

# ***Clear Roads: Developing a Totally Automated Spreading System***

## **Guides #1, #2 & #3,**

*February 27, 2014*

Prepared for:

Ashley Duran, Contract Administrator  
Minnesota Department of Transportation  
Consultant Services Section, Mail Stop 680  
395 John Ireland Boulevard  
St. Paul, Minnesota 55155-1899

Prepared by:

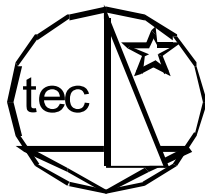

Thompson  
Engineering  
Company

3830 Rustic Place  
Saint Paul, MN 55126  
Tel: 651 260-0116

[www.statisticsinc.com](http://www.statisticsinc.com)



3830 Rustic Place  
Saint Paul, MN 55126  
Tel: 651 260-0116

Thursday, February 27 30, 2014

Ashley Duran, Contract Administrator  
Minnesota Department of Transportation  
Consultant Services Section, Mail Stop 680  
395 John Ireland Boulevard  
St. Paul, Minnesota 55155-1899

Dear Ashley Duran,

Please find attached the draft of the deliverable "1<sup>st</sup>, 2<sup>nd</sup>, 3<sup>rd</sup> Guides (one edition), the Automated Spreaders", part of the project "Clear Roads Developing a Totally Automated Spreading System."

Please review as needed. Comments, suggestions, and recommendations received from the Clear Roads staff will be incorporated in the final version.

Please contact me if you require additional information. Thank you for your consideration.

Sincerely,



Gregory E. Thompson

**TABLE OF CONTENTS**

Topic	Page
<b>Preliminaries:</b>	
Cover	1
Letter of Transmittal	2
Abstract	4
<b>Guide #1 Best Practices and Features of an Automated System</b>	6
I. General Introduction	6
II. Background	8
III. Capabilities and Best Practices	11
<b>Guide #2: Levels of Automation</b>	19
IV. Introduction to Levels of Automation	19
V. Level Zero: No Automation	23
VI. Level One: Sensor Driven Automation	29
VII. Level Two: Automatic Controller with GPS	31
VIII. Level Three: Automatic Controller With Remote Control and GPS	33
IX. Summary of Levels of Automation	38
<b>Guide #3: Challenges and Currently Available Systems.</b>	40
X. Introduction to the Systems	40
XI. Agricultural Technologies	40
XII. Challenges of Automation	42
XIII. Sources of Total Systems	43

XIV. Conclusion and Testing	55
<b>Appendices:</b>	57
XV. Bibliography	57
XVI. Survey Analysis Report	65

## Abstract:

This document is part of a three-guide series produced for the Clear Road's study: ***“Developing a Totally Automated Spreading System”***. The state of automation for winter maintenance chemical spreading is changing rapidly. There are many systems on the market for use right now. There are a number of systems from different manufacturers that will adjust the spread rate for pavement temperature and GPS location. In addition there are a number of other sensors on the market that can be used to further adjust the rate and pattern of the spread. All of the commercially available systems to date are autonomous, meaning the sensors and information used to change the spread rate are on board the truck. There are no remote control systems on the market that would allow control in real time to be exercised from headquarters.

After searching the literature, surveying the snow fighters and writing these guides, the opinion of these authors is that ***the most important future development for the use and implementation of this technology is a field test of the currently available systems.***

These guides have the following purpose/function:

- **Guide 1: Best Practices and Functions of Automated Spreading Systems.** This is an introduction to how the needs of snow fighters can be realized using the technology of automated spreading. Guide 1 also prioritizes which technologies are most useful and promising.
- **Guide 2: Levels of Automation.** A hierarchy is developed to discuss the increasing level of automation that is currently available. This allows the snow fighter to see where their current systems are in the hierarchy and what would be the next step towards automation. Also parts of a spreader system are detailed in this guide to further the understanding of the components of spreader automation.
- **Guide 3: Challenges and Currently Available Systems.** This is an overall look at the automated spreading system phenomenon. Technological and logistical challenges are discussed, along with an overview of how to test an automated system. In addition all known automated systems on the market are introduced and some comparisons are drawn.

The three guides together provide the snow fighter with an introduction to automated spreading solutions. In addition, the guides provide road maintenance personnel options for selecting snow and ice removal equipment to meet their level of service requirements.

# Guide #1 Best Practices and Features of an Automated System

## I. General Introduction

**A. General.** Departments of Transportation (DOTs) are constantly challenged to maintain safe, passable roadways through the winter season. Winter weather provides a variety of unique conditions that require specific and varying treatments in order to attain the desired results. At the present time, decisions regarding the best approach for treatment in any given situation are founded on some basic published application guidelines (FHWA 1996, NCHRP 2004).

**B. Situation.** The implications of improper treatment include failure to meet the customers' expectations, waste of materials, and adverse impact on the environment as well as public safety. See Figure 1. Among the multitude of factors influencing the effectiveness of treatment, the single most influential factor is the vehicle operator.

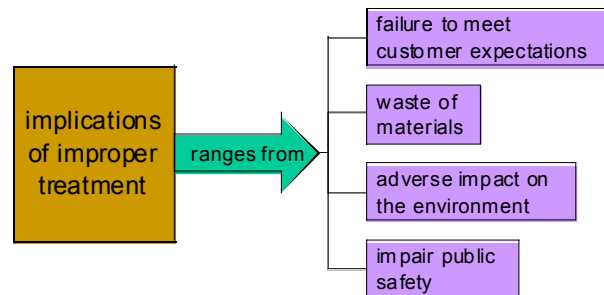

Figure 1: Improper Treatment Results

**C. Challenge.** Application rates and use of varying medium (i.e., granular vs. liquid or granular with liquid) are at present set and adjusted by the vehicle operator. As with any function under the control of a person, it is subject to error. It is the intent of this study to determine if a totally automated dispensing system is achievable and cost effective. The project objective is illustrated in Figure 2. Guides 1 and 3 discuss the totally automated dispensing systems that are available today and in the near future.

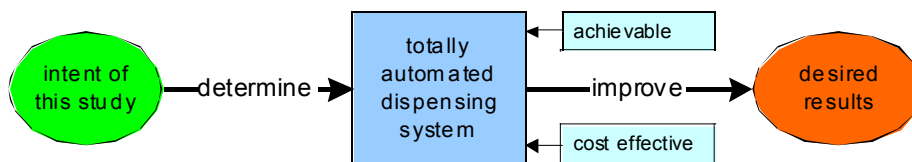

Figure 2: Project Objective

**D. Premise.** The earlier mentioned NCHRP report from 2004 states, "The findings of this research pointed out the importance of:

- (1) Ensuring that snow and ice control strategy/tactic combinations are level of service (LOS) driven;
- (2) Using nowcasting results [current weather information], materials characteristics, traffic volume, and cycle time considerations in the treatment decision making; and

- (3) Providing flexible winter maintenance operations to deal with the variety of precipitation types, especially those occurring within a given weather event.”

The premise here is that the ability to attain and maintain a given level of service during winter maintenance operations will be improved if a central agency/person/supervisor has overall control of the amount, type, and schedule of the actual materials distributed on to the roadways. Further, this can be accomplished by means of a *totally automated dispensing system* and appropriate accessory subsystems. The automated spreader must be able to respond to changing weather conditions and flexible enough to handle different spreading materials, traffic conditions and decision making strategies. To justify its cost it must be able to improve the consistency and the reliability of any given LOS.

There are two approaches outlined here to automate the snowplow. These can be termed autonomous (1) and remote control (2):

- (1) Make it a smart plow that receives and/or measures the available local factors and adjusts/dispenses the material as programmed using a locally controlled automated dispensing system. This system operates fully without headquarter’s input.
- (2) The other approach is to automate the snowplow and control it remotely so that the decision point is at a central location where the entire fleet is regulated by an experienced snow fighter using a centrally configured totally automated dispensing system. The trucks can be controlled/adjusted in a group or individually.

**E. Literature Search.** An informal literature search was completed to determine the status of automated spreading systems in the snow and ice removal equipment industry. See section IX (bibliography). Reviewing the literature revealed several varieties of automation available to the snow fighter today. These systems can be triggered by on-vehicle sensors, programmed for recorded route plans, and, in principle, adjusted remotely from a central location. This is covered in detail in the Guide #3.

**F. Survey.** In preparation for these guides, a survey of snow fighters was collected (see Section X, Appendix 1). One finding of this study is that most snow fighters (90%) think controlling the rate of chemicals spread on our roads is very important for road safety and for conserving chemicals (important for costs and the environment). Another finding shows the spread rate is determined about half the time by the drivers and half the time predetermined by the supervisor. Modern automated spreaders still have input from both the driver and the supervisor, but this input is added to the pre-programmed settings and the sensor data gathered along the route.

## II. Background

**A. General.** The desired level of service should drive winter maintenance actions. When the desired level of service includes bare pavement, bare wheel-tracks, or the equivalent, then some sort of chemical treatment is required. The strategy may be one of anti-icing (preventing the formation of a bond between the pavement and snow or ice) or de-icing (breaking the bond that has formed between the pavement and snow or ice.) In both cases, the goal is the ability to easily plow frozen precipitation from the pavement.

The strategy may use solid chemicals (ideally pre-wet rock salt – sodium chloride), liquid chemicals applied directly to the road surface, or slurries (a solid application with very high levels of pre-wetting liquid, often with some sort of crushing mechanism to crush the rock salt prior to pre-wetting). Regardless of the details of the chemical application, the goal is to get the right amount of chemicals to the right location, at the right time, and keep it there while it does the work of bond prevention or bond breaking.

**B. Level of Service.** When the snow fighters are tasked with keeping the roadways safe, they are making decisions about type and timing of road treatment or plowing based on a certain level of service (LOS). In a general sense, LOS is how clean or dry or clear of snow does the road surface need to be to ensure safety? In practical applications, it is providing a certain application per type of road network (Interstate, expressway, traffic route, back road as a function of volumes of traffic). See table 1 for an example of an application chart indexed with type of road classification.

ROAD CLASSIFICATION	TYPICAL	WINTER* SERVICE –(Level of Service)	DEICER	APPLICATION RATE KG/LANE-KM	TIME FRAME TO COMPLETE DE-ICER OPERATIONS
Expressways	DVP / FGGE	Bare Pavement	100% Rock Salt	250/500/640	2-3 cm snow& continuing 1-2 hrs
Arterials (minor / major)	Yonge St. / Sheppard Ave.	Bare Pavement	100% Rock Salt	250/500/640	5 cm snow 2-3 hrs
Collectors	Main Streets through sub-division	Centre Bare Pavement	100% Rock Salt	250/320	8 cm of snow& stopped 4-6 hrs
Locals	Residential (including dead end streets and industrial	Safe and Passable Pavement	100% Rock Salt	250/320	8 cm of snow + stopped 8-12 hrs



ROAD CLASSIFICATION	TYPICAL	WINTER* SERVICE –(Level of Service)	DEICER	APPLICATION RATE KG/LANE-KM	TIME FRAME TO COMPLETE DE-ICER OPERATIONS
	roads <2500 AADT**) )				
Laneways		Safe and Passable Pavement	100% Rock Salt	640	24 hrs

**Table 1: ROAD CLASSIFICATION – SALTING CHART from the City of Toronto**  
(<http://www.toronto.ca/transportation/snow/pdf/02smp.pdf>)

\* This is the desired condition of the pavement surface. However, it is necessary to have sufficient traffic volumes to activate and improve the characteristics or the de-icer. The time to achieve this condition will vary with the time of day, duration and intensity of the storm event.

\*\* Local roads > 2500 AADT under review

Automated systems allow the application rate (and pattern, etc.) to be changed en route using input from onboard sensors, GPS location and communications from headquarters. More or less chemical can be spread in certain locations automatically. This allows for a more consistent (and efficient) application that varies along the route as the storm changes and/or the road changes. Typical en route adjustments that are desirable and possible with automation are when the pavement temperature changes (onboard sensor) indicating a change in application rate or when spreading near a wildlife habitat (pre-programmed in the GPS route) that would require the application rate to be lessened or set to zero for a section of pavement. Ideally, the automated spreader should maximize consistency and efficiency within a certain level of service while minimizing costs and/or environmental impact.

**C. Example.** A number of reports (Ketcham et al., 1996; Blackburn et al., 2004) and several agencies have developed guidelines or systems that determine how much material should be applied during a storm (and, to a lesser degree, before a storm). For a predetermined level of service, Table 1 shows an application guide, developed and used by the Iowa Department of Transportation. The application rates in Table 2 are functions of the route cycle time, the pavement temperature, and the type of precipitation occurring.

Other systems, either fully implemented Maintenance Decision Support Systems (MDSS) or systems moving in that direction, include recommended actions for pre-storm treatments, in-storm treatments, and end-of-storm treatments. An automated spreading system should relieve the operator from having to continually adjust application rates during a storm, thus freeing the operator to keep “two hands on the wheel and two eyes on the road.”

Salt Application Rate Guidelines							
Pre-wetted salt @ 12' side lane (assume 2-hr route cycle time)							
Surface Temperature	(Fahrenheit)	32-30	29-27	26-24	23-21	20-18	17-15
Lbs of salt to be applied per lane mile	Heavy Frost, Mist, Light Snow	50	75	95	120	140	170
	Drizzle, Medium Snow ½" per hour	75	100	120	145	165	200
	Light Rain, Heavy Snow 1" per hour	100	140	182	250	300	350
Pre-wetted salt @ 12' wide lane (assume 3-hr route cycle time)							
Surface Temperature	(Fahrenheit)	32-30	29-27	26-24	23-21	20-18	17-15
Lbs of salt to be applied per lane mile	Heavy Frost, Mist, Light Snow	75	115	145	180	210	255
	Drizzle, Medium Snow ½" per hour	115	150	180	220	250	300
	Light Rain, Heavy Snow 1" per hour	150	210	275	375	450	525

**Table 2: Application Rates Used by Iowa Department of Transportation.** This is for a particular level of service. There would be a different application table for each different level of service. (see Table 1)

**D. Current Practice.** An optimal chemical program requires the application rate of chemicals to be adjusted for a variety of conditions. Current practice primarily adjusts the rate for a given storm but does not adjust the rate along a route to account for differences along that route. Partly this results from trying to avoid cognitive overload for the operator of the plow truck. It is enough to have to drive a large truck, with a plow on the front, in conditions of snow, wind, limited visibility and possibly icy roads, without having to adjust the material application rate nearly continuously along the route. While experienced operators may be able to make some such adjustments (often by way of a “blast” button), the number of such experienced operators appears to be diminishing as the workforce ages and many operators move into retirement (see for example, Cronin et al., 2011 and Spy Pond Partners et al., 2009).

In addition to the need to adjust (in the ideal) the application rate of materials to account for changes in pavement temperature (for example, upon crossing a bridge), there is also a need to adjust application rates (and perhaps spread patterns) to account for turn lanes, bus pull-outs, and other road features. Requiring an operator to make such adjustments is a significant cognitive burden on an already taxed operator. Insofar as this burden can be reduced, safety will be enhanced and operator fatigue will be mitigated.

In brief, the desired end product would be able to adjust automatically for current and forecast weather and road pavement conditions. It would incorporate route cycle times and adjust application rates if cycle times were impacted by severe weather or heavy traffic. It would

adjust application rates according to variations in temperature and shading along a route. It would adjust spread patterns and rates to accommodate various road features and environmentally sensitive areas, etc. These aspects are explored further in the following section.

As detailed in the “Sources of Total Systems” section, some of these desired products are available and being implemented (like a pavement temperature sensor being used to trigger spread rate changes), some are available and being tested (like GPS recorded route systems – see the Danish study by Bo Summer) and others like the remote control/headquarters control systems are not available yet.

### III. Capabilities and Best Practices for Automated Systems:

Table 3 lists the desired system capabilities of a fully automated spreader system. Inherent in Table 3 are assumptions about what is needed in an automated spreader. Ideally, such a system would adjust application rate to take into account the variables identified in Table 2 (cycle time, storm type, pavement temperature range). The ensuing discussion assumes that this application rate can then be further varied according to certain parameters discussed below.

Desired System Capabilities for a Fully Automated Spreader System
<ul style="list-style-type: none"> <li>Automated setting of an average application rate</li> </ul>
<ul style="list-style-type: none"> <li>Automated variation from average application rate as a function of road surface temperature</li> </ul>
<ul style="list-style-type: none"> <li>Automated variation from average application rate as a function of location</li> </ul>
<ul style="list-style-type: none"> <li>Automated variation from average application rate as a function of current weather conditions</li> </ul>
<ul style="list-style-type: none"> <li>Automated variation from average application rate as a function of forecast weather conditions</li> </ul>
<ul style="list-style-type: none"> <li>Automated variation in spread pattern as a function of location</li> </ul>
<ul style="list-style-type: none"> <li>Automated variation from average application rate as a function of traffic conditions</li> </ul>
<ul style="list-style-type: none"> <li>Automated recording and archiving of what material was applied where, and when</li> </ul>

**Table 3: Desired System Capabilities.** Although the table lists these controls individually, modern automated spreaders are capable of more than one of these controls. For example, a ground speed control and a pavement temperature sensor could work together to determine the application rate.

### **A. Automated Setting of an Average Application Rate.**

Using a suitable variant of Table 2, the system should be able to determine a standard application rate for a given cycle of application by the vehicle. In other words, using cycle time, storm type, and pavement temperature range, an application rate is set. As an example, cycle time could be linked to a given plow route, and a number representing that plow route could be entered allowing the controller to access the relevant information and use that information in a look-up table to figure the base application rate.

The benefit of this approach is that it allows the system to access information along the route where changes in either application rate or spread pattern would be needed. The drawback is that to some degree it reduces the flexibility of the plow – if it is called to assist on another route, additional information must be provided. The alternative approach is for the operator of the truck (or possibly a supervisor) to enter cycle time prior to leaving the maintenance depot. Both approaches may be suitable in certain circumstances, so both will be considered going forward.

Storm type and pavement temperature can be entered by the operator (again, before leaving the yard) in the truck, or by a supervisor remote from the truck, depending on the desired mode of operation. It is envisaged that this part of the process would not require a great deal of accuracy in the pavement temperature, but rather just a range (as in Table 2).

This combination of variables allows for the average application rate for a given route, in a given storm, with a given range of pavement temperature to be set. This application rate can then be refined, as discussed below, to take advantage of additional information.

### **B. Automated Variation from Average Application Rate as a Function of Road Surface Temperature.**

At any given location on a plow route, the road surface temperature will have a certain value which at least initially will be within the range set at the maintenance facility. As a truck progresses through its route, however, the road temperature may change. For example, if a truck has a route that goes significantly uphill from the facility, it is a reasonable expectation that the pavement temperature would change. As time passes the weather will change and this too may result in a change of pavement temperature. The application rate should be adjustable on the basis of the pavement temperature sensor linked to an automated delivery system on the truck.

How much should the application rate be adjusted from the initial setting? This can be determined by interpolation between values in Table 2 (or whatever the equivalent is determined to be for a given agency). For example, a supervisor decides for a given storm with a pavement temperature of 28° F and a medium snow fall, the application rates for the trucks should be 150 pounds per lane mile (implying a three hour cycle time from Table 2). Then if the

temperature falls into the range of 24-26° F, the application rate would be automatically increased to 180 pounds per lane mile in order to maintain the level of service.

**C. Automated Variation from Average Application Rate as a Function of Location.**

Some locations on a route might require a reduced (or possibly an enhanced) level of chemical application. For example, amounts may need to be adjusted for shaded areas, intersections, bridges over bodies of water, etc. Some agencies require reduced or no salt application on new bridge decks for periods of up to two winter seasons. This type of variation requires a localized level of service for different parts of the route to maintain a constant quality of coverage.

Considering environmental concerns, if a certain area is particularly close to a wetland, it may be that salt application must be minimized in this location (see Figure 3). In such conditions, the system settings would be pre-entered to provide a reduced application rate for that section of the route (most likely prior to the start of the winter season). Then, when the truck approaches this area, application rates would be decreased by a certain preset percentage, until the truck had passed through the area. This approach not only reduces the cognitive load on the truck operator, but also ensures that the rate of application is reduced in the environmentally sensitive area.



**Figure 3: An Area of Reduced Salt Application**

#### **D. Automated Variation from Average Application Rate as a Function of Current Weather Conditions.**

The average application rate is set when the truck leaves the yard (see Table 2) but during a storm the weather can change. This change may be minor or significant. A freezing rainstorm could change to snow or vice versa. The wind could strengthen. Issues of changing road temperature are discussed above, but these clearly are a facet of the changing weather situation.

As the weather changes, the application rate may need to change also. A light snow that changes to freezing rain could require a 40% increase in application rate (see Table 2). The challenge in this case is how best to make the change. The operator is experiencing the current weather, but it may not be realistic to expect the operator to make fine distinctions between weather conditions. Automating the process of change to account for variable current weather conditions would require excellent current weather condition information along a route.

It should be noted that the nature of weather in a storm is highly variable. This raises an additional concern because changing application rates due to such changes in weather may result in uneven application along a route due to the movement of the storm itself, perhaps in the general direction of the plow route.

Given these factors, the best approach would appear to be to limit such changes to major shifts in the weather and to trigger such changes centrally rather than within the truck. If a storm changes over to freezing rain from snow, an appropriate signal could be sent to the trucks out plowing to adjust their application rates accordingly requiring remote control-type automation.

#### **E. Automated Variation from Average Application Rate as a Function of Forecast Weather Conditions.**

It takes a truck a finite amount of time (typically on the order of two to three hours) to complete one full circuit of a maintenance route, or one cycle. As indicated in Table 2, the application rate is a function of the cycle time (the relationship is direct in Table 2 – the application rates on the 3 hour routes are 1.5 times higher than those on the two hour routes). If the weather changes during the plowing cycle, then the material placed at any given spot along the route must be sufficient to cope with the changed weather conditions.

This raises the possibility of using a short term (3 to 6 hour) forecast to determine what the application rates should be on a cycle as a function not only of the current weather but also of what the weather will be during the cycle time. There are a number of challenges with such an approach.

First, while the accuracy of forecasts improves with a reduction in the time period over which the forecast is made (so a forecast of weather six hours from now will in general be more

accurate than one for the weather 24 hours from now), forecasts are still not accurate all the time, and the parameter that is most critical to winter maintenance (pavement temperature) is especially difficult to forecast accurately.

Second, significant changes in the weather over short periods of time (such as two to three hours) are not usual, although when they do occur, the ability to adjust rapidly is a definite benefit.

Finally, there is a challenge involved in translating the forecast into terms that can be used by the spreader controller on the truck. There would need to be some clearly identified trigger levels for changing the application rates and it is unclear at present whether there exists sufficient literature on rapid changes in winter storms to accurately identify such triggers.

#### **F. Automated Variation in Spread Pattern as a Function of Location.**

Certain locations on roads require a change in spreading patterns if the whole road surface is to receive an appropriate chemical application. Examples of this might include junctions, entrances and exits from roundabouts, bus pull-outs, on-ramps and off-ramps, and similar geometric variations. Anytime the width of a lane changes significantly (by 10% perhaps) benefit is derived from adjusting the application rate.

However, merely applying the chemical over the road surface in these wider areas is not sufficient. To be fully effective, these areas must be plowed prior to the chemical being placed. Chemical landing on standing snow is used up before reaching the target of the interface between snow and pavement.

Clearly, locations requiring adjustments in spread patterns can be marked using data from GIS databases. This information can then be provided to the spreader systems on the plow trucks. As indicated elsewhere, studies in Europe show that current-generation spreaders are not as good as might be desired in their ability to adjust spread patterns due partly to responsiveness. This can be addressed by allowing the system to anticipate arrival at the location where the spread pattern must be adjusted. If it takes 1.5 seconds for a system to adjust the spread pattern to a new configuration, this adjustment would begin 1.5 seconds prior to the estimated arrival at the location requiring the new configuration. Similarly, the new pattern can be “switched off” 1.5 seconds before the end of the location to ensure that chemical is not spread inappropriately.

The benefit of this approach is that it allows the system to access information along the route where changes in either application rate or spread pattern would be needed. The drawback is that to some degree it reduces the flexibility of the plow – if it is called to assist on another route, additional information must be provided.

### **G. Automated Variation from Average Application Rate as a Function of Traffic Conditions.**

In urban locations especially, the cycle time for a given route is often a function of the traffic level (which itself is a function of the time of day and road/weather conditions). Since heavy traffic will also serve to slow down the plow trucks placing material on the road during the snowstorm, such traffic increases the cycle time. It is straightforward to measure the average speed of a plow truck, and if traffic levels are a concern, the application rate can be increased by a certain percentage as the average speed of the truck drops below some threshold level. This may sound a bit contradictory at first but the spread rate is being adjusted already for ground speed on most trucks. The rate will be decreased with the decreased speed but must be increased because of the need to spread more with the longer cycle time.

This would be akin to moving the application rate from the upper to the lower table in Table 2. As noted previously, longer cycle times require higher application rates even when the mileage of the route is not changing as in the case of heavy traffic. The reason a longer cycle time requires a higher application rate is the greater opportunity for the salt applied to dilute out and refreeze. Adjusting the rate is done to maintain a given LOS over the course of many route cycle times.

### **H. Automated Recording and Archiving of What Material was Applied, Where, and When.**

Given that the spreader envisaged herein will have full GPS capability, any action taken by the spreader can be linked to a location and a time. Accordingly, the rate of application at any given location can be recorded. One possible challenge exists in this regard. For the best possible measure of application rate, two relatively independent measures of the rate should be obtained: the set point on the controller and the data from a sensor in the spreader measuring the weight of the remaining material.

Notwithstanding this challenge, such archived data can be extremely useful, especially in terms of risk management (i.e., dealing with potential lawsuits.) Various systems exist today that can collect the data from the truck either wirelessly or by USB stick, moving a shed towards paperless record keeping.

### **I. Overall Evaluation.**

If desired, all of the capabilities detailed in the previous sections could be achieved. Table 4 shows the possible priority that could reasonably be assigned to each of these capabilities, as judged by a subjective evaluation of their potential benefits and potential costs.

<b>Priority Level</b>	<b>Capabilities</b>
<b>First</b>	Automated setting of an average application rate



Priority Level	Capabilities
	Automated recording and archiving of what material was applied where, and when
<b>Second</b>	Automated variation from average application rate as a function of road surface temperature
	Automated variation in spread pattern as a function of location
	Automated variation from average application rate as a function of traffic conditions
<b>Third</b>	Automated variation from average application rate as a function of location
	Automated variation from average application rate as a function of current weather conditions
	Automated variation from average application rate as a function of forecast weather conditions

**Table 4: Priority Levels for Novel Capabilities.**

(This table is only a suggestion based on a general perceived need.)

Each snow-fighting group needs to evaluate which type of automation would benefit them the most and would be the most cost-effective. For example, in mountainous regions where the pavement temperature may vary a lot due to elevation, a sensor that monitors this variable and triggers spread rate changes would allow a significant improvement in the efficiency of chemical use. In an urban area where there are many intersections, bridges, differing numbers of lanes, etc. a GPS-recorded-route-type system may not be a good choice due to the lack of accuracy needed to handle the frequency of change.

It is noteworthy that different controller manufacturers appear to fall into three different philosophies with regard to automation. Group 1 seems to have stopped with the closed-loop ground speed automation system, although they may have many superficial bells and whistles attached to it. Group 2 is a mixture of philosophies. Group 3 is experimenting and offering products with higher levels of automation (pavement sensors, GPS, etc.) It is the opinion of these authors that the controller manufacturers in Group 3 would offer the most options in the future in the automation field.

	Ground speed controller closed loop	Pavement Temperature sensor control	GPS recorded route control
<b>Group 1</b>			
Force America	Yes	No	No
Dickey-john	Yes	No	No
Cimlineya	Yes	No	No
Romaquip	Yes	No	No
<b>Group 2</b>			
Bosch Rexroth	Yes	Yes	No

Monroe	Yes	Yes	No
Multidrive	Yes	No	Yes
<b>Group 3</b>			
Giletta	Yes	Yes	Yes
Küpper-Weisser	Yes	Yes	Yes
Epoke	Yes	Yes	Yes
Cirus Controls	Yes	Yes	Yes
Falköping	Yes	Yes	Yes
Nido	Yes	Yes	Yes
AEBI Schmidt	Yes	Yes	Yes

**Table 5: A comparison of controller manufacturers.** The type of automation offered is expressed in a simplified form. The situation is more complicated as many factors like CAN bus utilization and data logging techniques affect a manufacturer’s automation-ready status as well.

## Guide #2: Levels of Automation

### IV. Introduction to Levels of Automation:

This guide presents the different levels of automation that are available for salt spreaders. This is done in a way that goes from simple to complex, from non-automated to totally automated. The purpose is to allow snow-fighting personnel to find where their operation is in the spectrum of automation and see what innovations or improvements they could make to improve the level of service (LOS) they provide.

At each level of automation we will introduce and discuss the components needed to produce this type of automation and spreading.

Since this guide is primarily about automating the salt spreading function, the discussion will be centered on the spread controller and other parts of the truck as necessary to understand how the controller operates. From Monroe Truck’s website the following types of spreader systems are available.

<b>Tailgate</b>	Under-tailgate and replacement tailgate spreaders are low cost and dependable. Can be used with 1-ton through heavy-duty truck chassis.
<b>V-Box</b>	Slip-in or chassis mounts available. Designed for medium and heavy-duty truck chassis.
<b>RDS</b>	A radius dump body with the versatility to be a spreader. Designed for heavy-duty truck chassis.

**Table 6: Truck types from Monroe.**

Of course all of these types of spreader trucks and systems can be automated given the right controller and auxiliary equipment. Some capabilities will be different given the different delivery systems, etc. but in principle they can all be automated.

Automation in any application is all about communication and feedback. This is illustrated in Figure 4, where all of the automations discussed in this guide are depicted.

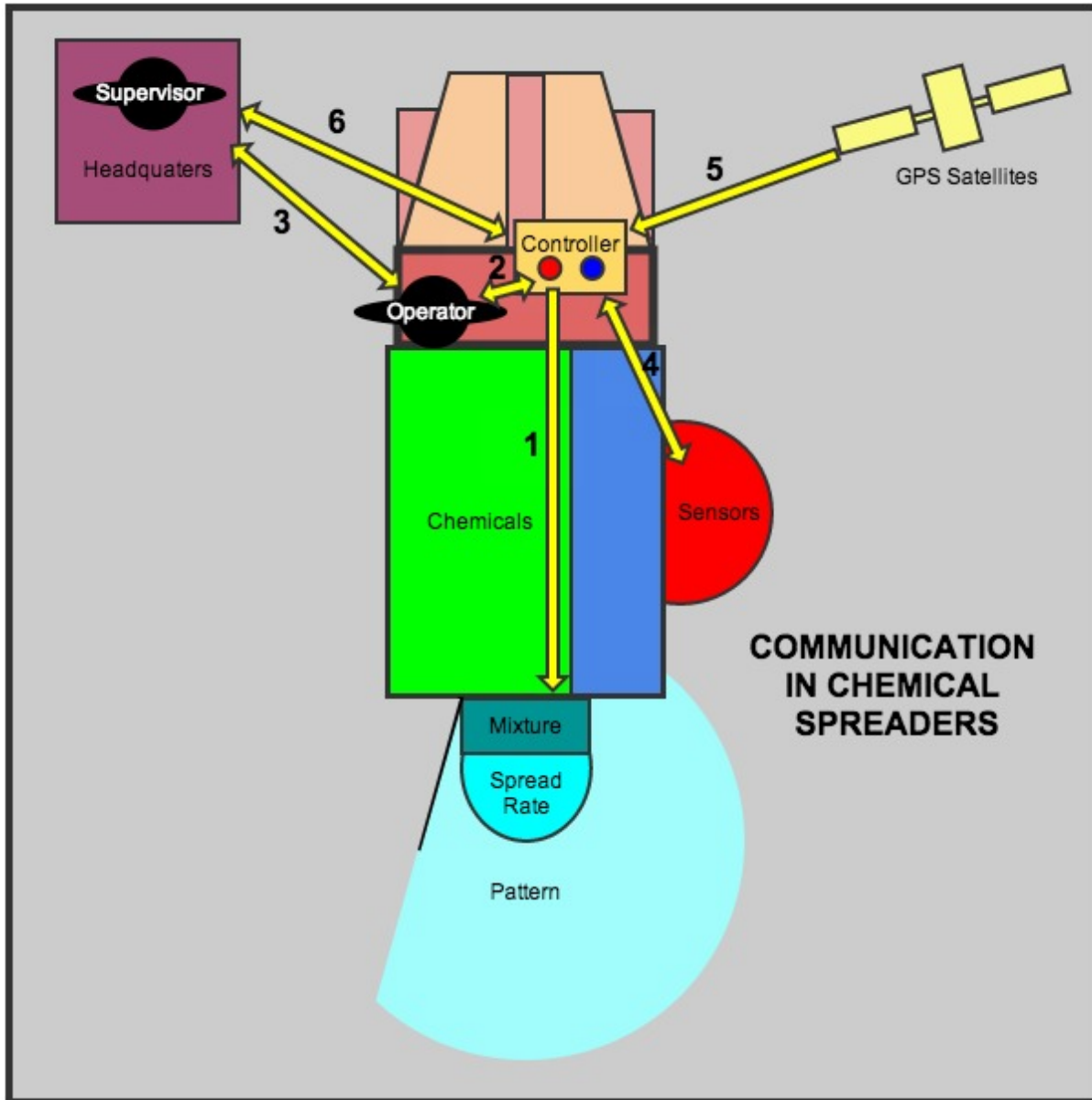

**Figure 4: Communication in chemical spreaders**

- 1) The controller controls the delivery system.
- 2) The operator controls the controller.
- 3) Headquarters controls the operator.
- 4) Sensors deliver information to the controller.
- 5) GPS allows the spreader to use position-specific treatments.

6) Headquarters can control the spreader directly from a remote location.

## Spread Controllers

The spread controller (Figures 5 and 6) is the key element for implementing automatic spreading capability for snow and ice removal. State-of-the-art spread controllers are computer-regulated devices. They are programmed with firmware and are capable of remote control, data downloads, capturing usage data, and interfacing with a communication device such as a cellular modem. The essential feature of these spread controllers is that they can be programmed to reconfigure the spread rate or material output when triggered by an external sensor. These technologically advanced systems are ready for any weather conditions. They can be programmed with multiple presets of up to six application rates for up to four materials. In addition, most spread controllers allow you to fix minimum and maximum rates and set an incremental rate within that range. Other features include automatic override and a built-in ground speed sensor to counter any technical breakdowns.



Figure 5: Spread Controller Example



Figure 6: Spread Controller Example

As mentioned above the discussion here will focus on the controller. We will delineate four levels of automation.

- Level Zero: No Automation. The operator makes all adjustments in real time.
- Level One: Sensor Driven Automation. The most common are closed-loop, ground-speed systems.
- Level Two: Position Driven Automation. Typically the route is driven before the storm and the GPS is recorded along with the spreader settings, then the route can be replayed as it is driven in the storm.
- Level Three: Remote Control Automation. This is not a commonly available product but there has been some research. Weather, traffic and emergency information can be used to adjust spreader variables from headquarters.

Commercially available spread controllers with most of these types of automation are listed in Table 7.

Manufacturer\Level	Zero	One	Two	Three
Epoke	Igloo S2400, Igloo S2300	S3800 Sirius AST	EpoSat	
Force America *		SSC5100 Spreader Control 5100ex Spreader Control		
Varitech Industries			Electronic Application Controller, Model MT403V-II **	
Cirus Controls		Dual Spread™, EZ SpreadPlus™	SpreadSmartRx™	
Component Technology (more than one manufacturer) *		ACS, AS2, AS3, GL-400, DS2, MS2		
Dickey-john *		LT Control™, ICS2000 Control, Flex4 Control, Control Point®		
Falköping		C-312	Scania Interactor or PDA	
Bosch Rexroth *		CS 550, CS 440, CS430, CS 425, CS 420 Spreader Controllers		
AEBI Schmidt		Thermologic	Autologic, Smart WinterCare***	

**Table 7: Examples of spreaders commercially available at each level of automation.**

As the level of automation increases usually more options are added to the controllers, like multi-material features, more control of the spread pattern, wireless features, etc. (all requiring auxiliary hardware).

\* These manufacturers offer models with many different features, but with regard to automation, all their models perform the same in principle.

\*\* This model claims to have some remote control possibilities, but these authors were unable to verify this completely.

\*\*\* This model, though still not technically in level three, has many “live monitoring and data archiving features that make it very advanced” according to the manufacturer.

## V. Level Zero: No Automation

Most controllers in use today have some automation (like ground speed control), but it is instructive to begin with a system with no automation. The driver has a controller in the cab, with which he/she directly controls the spreading. The operator can, of course, communicate with headquarters via radio and/or cell phone for instructions and guidance. Figure 7 illustrates the Level Zero scenario.

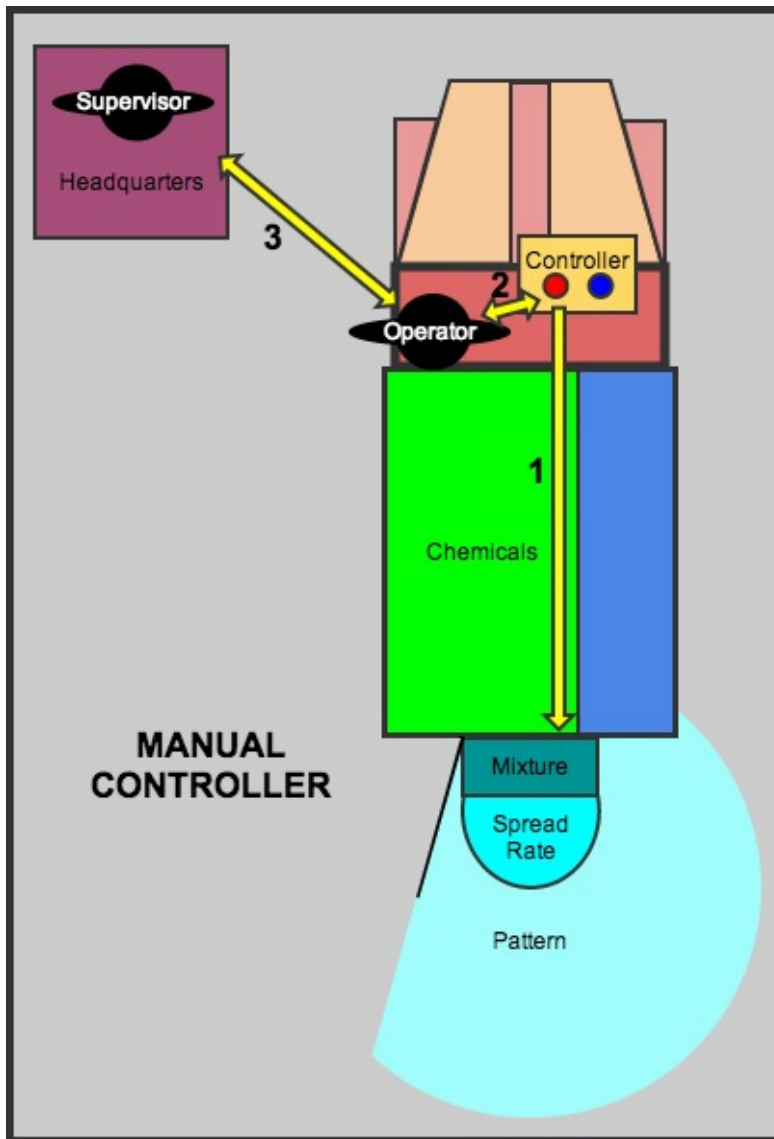

**Figure 7: Manual Controller.** 1) The controller controls the spreader. 2) The operator controls the controller. 3) Headquarters can advise the operator.

Modern spreaders have the ability to adjust the mixture of chemicals spread, the amount spread and the pattern of the spread. Currently, research and experimentation are being conducted with the velocity of the material (see “zero velocity spreaders”) and the height of the spinner/dispenser off the pavement. In the above figure the different chemicals to be mixed are symbolically depicted as blue and green and the other parameters of the spread by “mixture, spread rate and pattern”. The operator adjusts these parameters while he/she is driving.

## Components:

The components necessary for a non-automated system (which are part of all the automated systems as well) can be divided into two categories: power source and delivery system.

### A. Power Source:

Although there are a few choices for how to power a spreader system - electric, pneumatic, fuel and hydraulic - the vast majority of products are of the hydraulic type. Electric motor driven spreaders are relatively new but in principle could have some advantage in the areas of lower cost installation and faster response time (which is a critical variable in the automation arena.) For example Henderson has an all-electric product (see Figure 8).



**Figure 8: Henderson’s Electric Spreader:** details can be found here <http://www.henderson-mfg.com/charge.html>

**Hydraulic Powered:** The vast majority of snow fighters use a hydraulic powered system. It is important to understand the basics of how a hydraulic system works to understand factors such as response time, closed-loop sensors, etc. Truck-mounted hydraulic systems, regardless of their application, have in common the basic components and operating principles of any hydraulic system. They utilize a power source, reservoir, pump, directional control valve, and

actuators to move and control fluid in order to accomplish work. Every hydraulic circuit begins with mechanical power in the form of a rotating shaft, converted to hydraulic power with the pump, directed with a valve to either a cylinder or a motor and then converted back to mechanical power. Fluid power is ideal because one can easily divide, direct, and control the application of force. To perform work hydraulically requires the presence of two conditions, flow and pressure. If either is eliminated, work stops. Alternately, controlling flow and pressure allows control of hydraulic work. A basic hydraulic system can be seen in the line drawing shown in Figure 9 and the function of each part is described below.

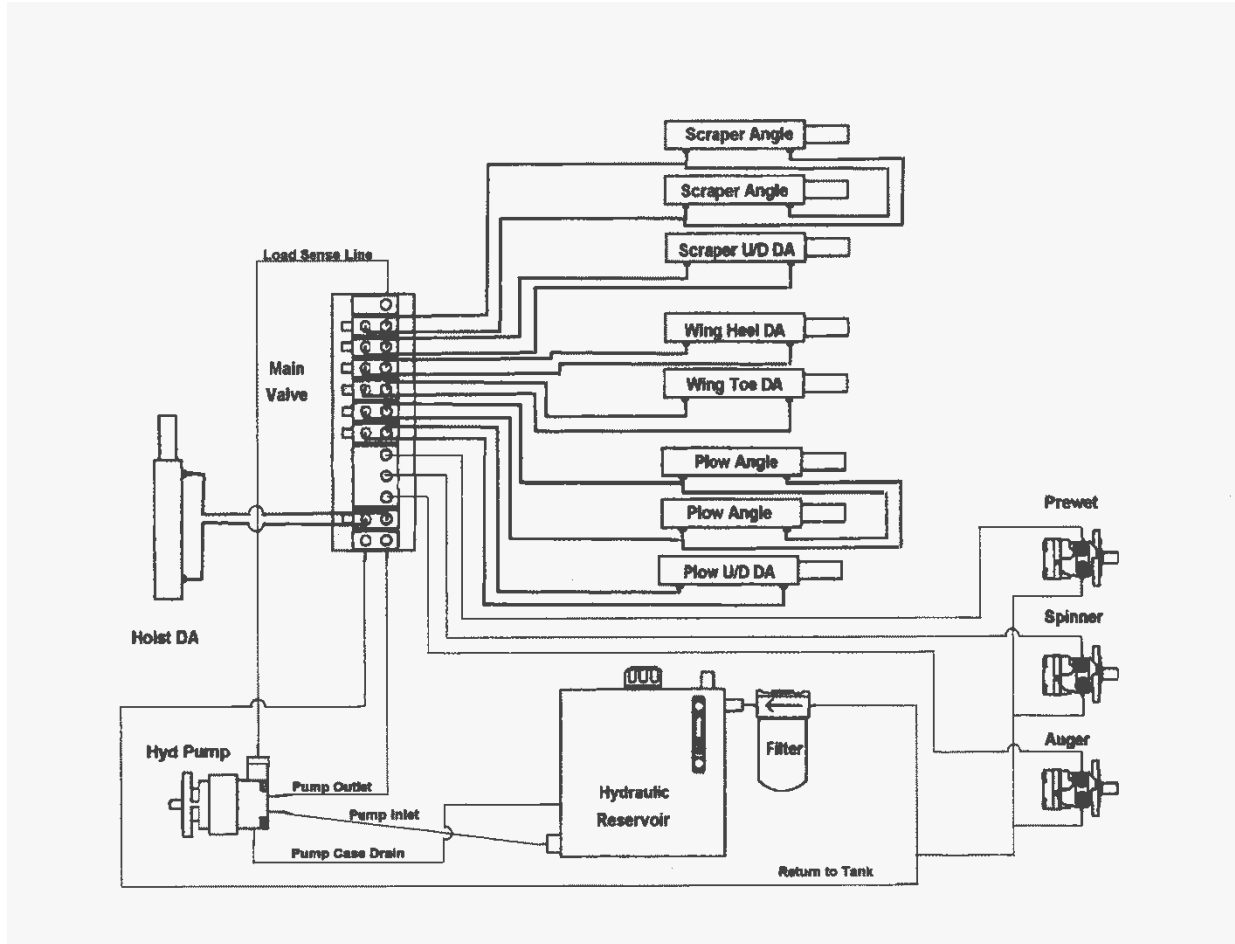

Figure 9: Line Drawing of a Basic Hydraulic System

**1. Pumps.** Hydraulic pumps take the mechanical energy of the prime mover (a turning force) and convert it to fluid energy in the form of oil flow. This oil flow is usually measured in gallons per minute (gpm) and determines the operating speed of the system. As far as the hydraulic system is concerned, any pump which meets the flow and pressure requirements will work equally well. See Figure 10 for an example image.

**2. Control valves.** The control valves direct the oil flow produced by the pump to the various actuators (cylinders and motors) of the system and/or back to tank. Directional control valves



are specified according to the volume of oil flow they must carry, operating pressure, and number and type of work sections required. See Figure 11 for an example image.

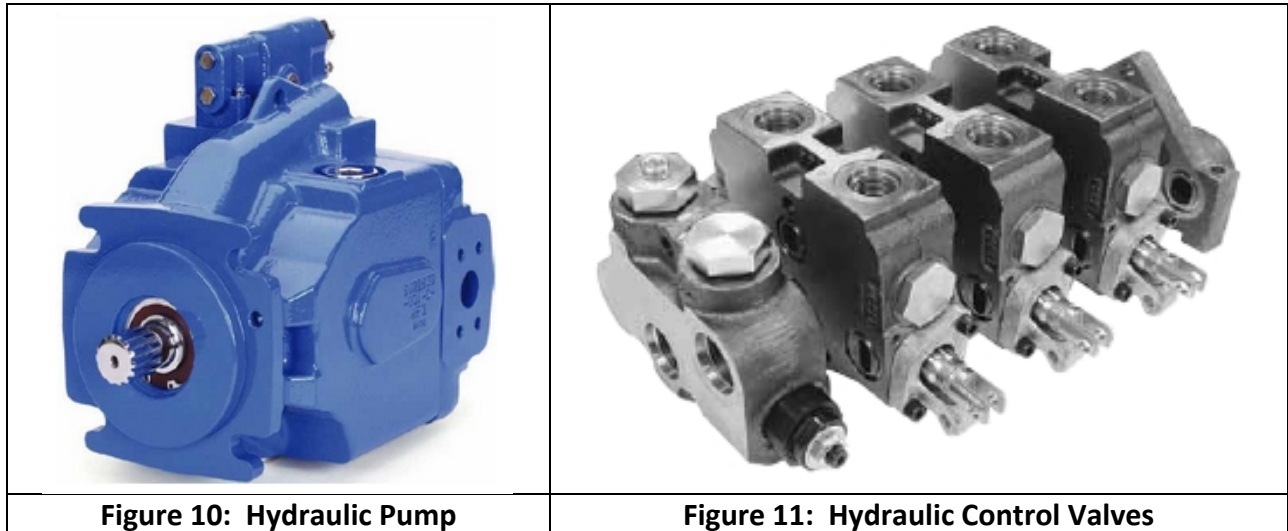

**3. Actuators.** The actuators are the hydraulic components that actually perform the physical work in the system. They are the components that convert fluid power back into mechanical power. Hydraulic cylinders and motors are the system actuators. Hydraulic cylinders convert fluid power into linear motion to raise a dump body or angle a plow. A drawing of a simple actuator is provided in Figure 12.

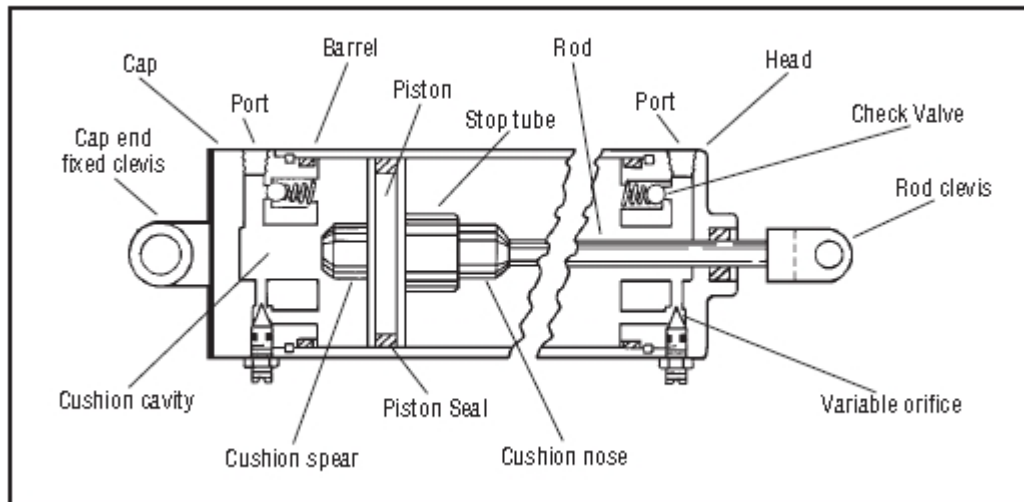
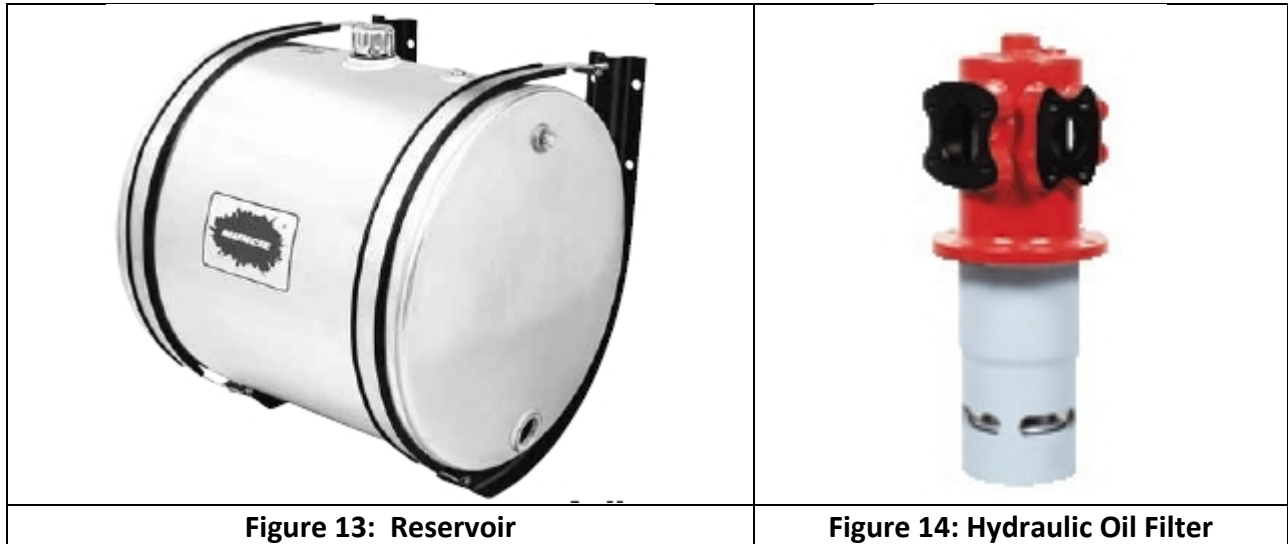

**Figure 12: Hydraulic Cylinder (Actuator)**

**4. Reservoirs.** Reservoirs (Figure 13) serve three purposes in the hydraulic system: they store the oil until the system requires it, they help provide for the cooling of the oil, and they provide a place for contaminants to “settle out” of the oil. Oil reservoirs can be constructed from steel, aluminum, or polyethylene plastic. Each of these materials has benefits and drawbacks. The

primary job of the reservoir is to provide oil to the pump. Therefore, the ideal location is close to and directly above the pump's inlet port. While possible in an industrial setting, this is often impractical to achieve in a truck-mounted system.

**5. Filters.** Filters (figure 14), properly selected and maintained, will prevent contaminants from damaging hydraulic components and enable the system to run cooler, quieter, and longer. Filters may be located in the pump's inlet, pressure line, or return line.



**6. Hoses & Connectors.** Hydraulic hoses and connectors must be the proper size and type to carry the oil at the specified rate of flow and pressure.

### **B. Delivery Systems:**

Delivery systems are comprised of a three-step process: getting the material out of the storage unit (augers and conveyors), mixing the material, and dispensing the material (spinners, etc.) All of these systems have the potential to be automated.

**1. Auger.** An auger (Figure 15) is used in the bed of a v-box spread system to move granular material from the box to the rear of the truck in order to gravity feed the spinner.

**2. Conveyor.** A conveyor (Figure 16) spreads a wide variety of material including all types of aggregate and hot mix asphalt. It can also perform shoulder maintenance, rut-filling, asphalt-patching and ice control.

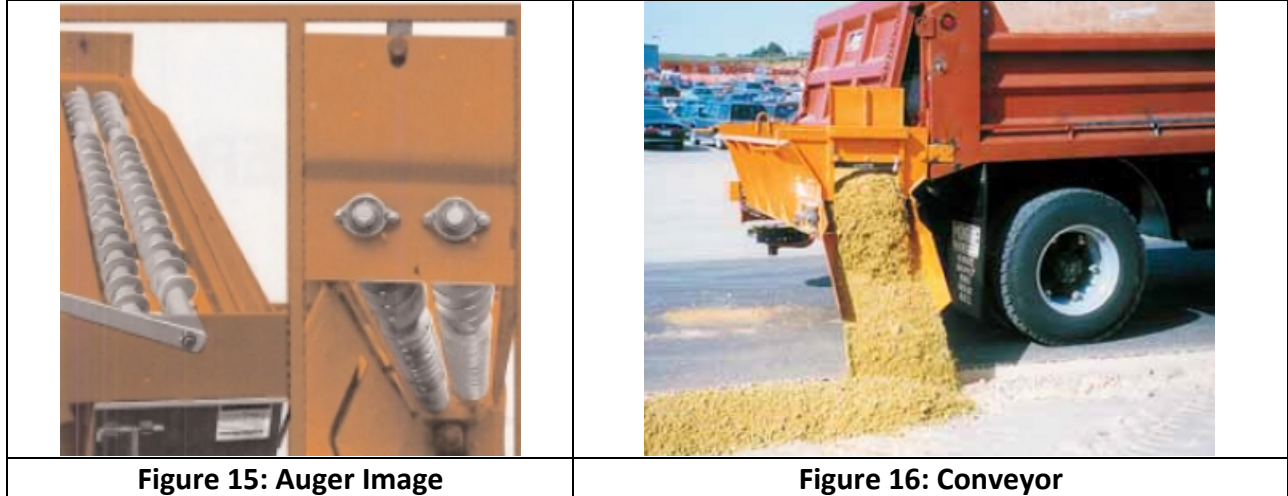

**3. Spinners.** A spinner (Figure 17) enables accurate placement of granular and aggregate materials for snow and ice removal. A typical adjustment here would be the speed of the spinner, allowing greater control of the width of the spread pattern. More subtle adjustments like height of the spinner and wings to block and direct the salt are also being used and experimented with. Finally, zero velocity dispensers (see Figure 18) have been shown to reduce the amount of salt that bounces off the road following application.

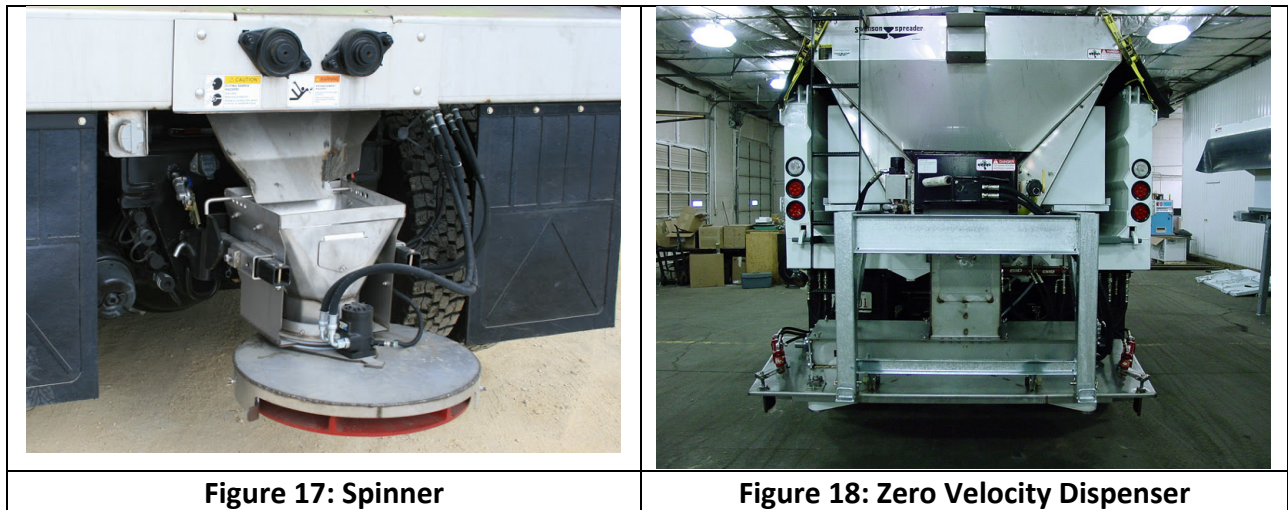

## VI. Level One: Sensor Driven Automation

In addition to driving the truck and communicating with headquarters, the operator has the daunting task of controlling mix, amount and pattern in real time. Without automation, most of these parameters are set beforehand and cannot be varied throughout the route. This can waste materials and/or compromise level of service concerns giving rise to the need to automate some or all of these controls.

The first level of control is a sensor driven control. The controller in the cab takes input from different sensors on the truck and accordingly adjusts the mix, amount and pattern of the spreading. There are two types of sensors that provide input to the spread controller, open-loop and closed-loop. Figure 19 illustrates these in a general way.

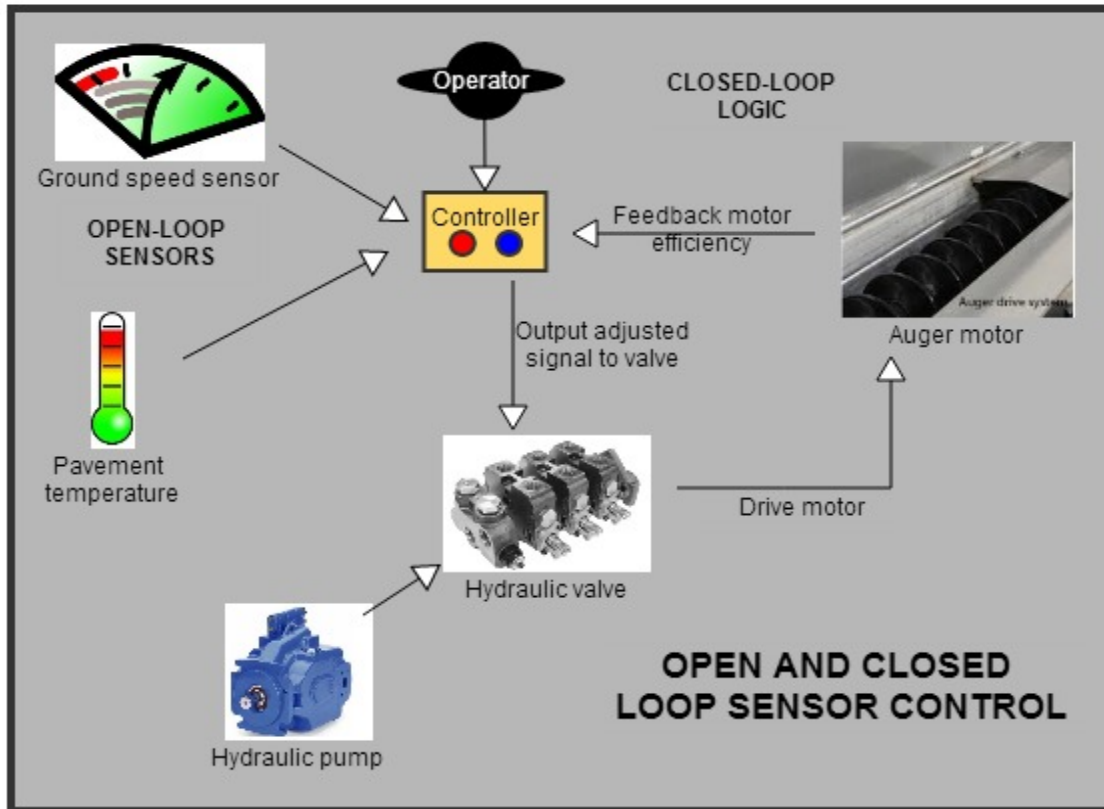

**Figure 19: Open and Closed Loop Sensors:**



An open-loop system monitors some variable like the truck speed or the pavement temperature and adjusts the control valve to a predetermined setting to provide the correct belt or auger speed for the desired spread rate. A closed-loop sensor has the controller set the rate or position of some aspect of material delivery (like auger speed) then measures the rate or position independently and, in turn, feeds this back into the controller to readjust and refine the rate or position. For example, actual auger speed can vary over the length of a route (with

different amounts of material present) or over the life of the unit (with wear and tear on the hydraulic system). Such hydraulic inefficiency of the auger can be constantly monitored and the auger hydraulic valve can be adjusted in the automated, closed-loop, ground-speed system.

In addition to the open and closed loop ground speed automated systems in use, another popular sensor is the pavement temperature sensor. This sensor can adjust the amount of material spread based on pavement temperature (in particular being sensitive to whether the pavement is below or above 32 degrees F).

### A. Components (Sensors):

There are several sensors that are employed by snow fighters to collect data on material distribution and storm history information. These same sensors can be used to trigger a change in road surface treatment. The most commonly used for automation are speed or engine RPM, pavement temperature, and GPS or location sensors. GPS is unique and will be discussed in the next section. See Table 8 for specifics of some available sensors.

Sensor	Description
	<p><b>Vehicle speed or engine RPM Sensor.</b> Uses speed to determine automatic spread control. These are prevalent in the industry and are referred to as ground speed controlled. It changes the spread rate based on the speed of the vehicle, that is, as the vehicle speeds up, the system outputs more and as it slows down and/or stops, it decreases the flow of granular material. Most vendors have a spread controller that implements ground speed control. This type of change of spreading rate is to compensate for speeding up and slowing down along the route and is not for overall average speed which would figure into the route time as discussed earlier.</p>
	<p><b>Pavement or surface temperature sensor.</b> By using an infrared pavement temperature sensor, the spread controller can be triggered to respond by changing spread rate, adding pre-wet, or hitting the blast button. There are several vendors that offer this feature in their spread control distribution systems.</p>

Sensor	Description
	<p><b>Friction Meter or Grip Tester.</b> Measuring the “grip” of the road surface is an indicator of the snow &amp; ice removal effectiveness in making the roadway safer for the motoring public. The friction value can be used to control the chemical treatment of the roadway based on assessing the torque between the road surface and the friction wheel, adjusting the treatment accordingly.</p>
	<p><b>Salinity Tester.</b> A few working models of this device have been tested during the last decade with mixed results. Testing the potency of the treatment mixture has promise in controlling the amount of chemical used on the roadway during severe storms. This type of sensor is capable of sending a signal to the spread controller that measures the amount of salinity from the road spray so as to leverage previous treatments when re-visiting snow &amp; ice removal sections of the roadway.</p>

**Table 8: Examples of Sensors to Control Automatic Spreading.**

The first two examples, speed and surface temperature, are in wide use, and the second two, friction and salinity, are more experimental

There are other sensors that can be employed such as plow position, traffic, time of day/season, and type of material. These sensors are not addressed as part of the automatic spreading capability for this study.

## VII. Level Two: Automatic Controller with GPS (and/or sensor input)

Employing a GPS (Global Positioning System) sensor to determine location of the spreader system, the spread controller can be triggered to respond based on vehicle position/locality or mile marker. The spread controller can be programmed to vary rates based on lane position, bridge decks, and/or hills/intersections. There are only a few vendors that have this feature available, although interest is increasing. The technology is mature enough to accomplish this type of automatic spread control especially in rural areas where the terrain doesn’t change rapidly.

The controller is connected to GPS which inputs the location of the truck and uses this data to adjust the mix, amount and pattern of the material to be spread. The route’s GPS, amount spread, spread pattern and anything else are theoretically pre-programmable. This is done by running the route before the storm and recording the adjustments. During the storm, the route

is driven according to the GPS instructions and the spreader is automatically controlled based on pre-programmed settings. With the GPS feature, data can be recorded with a location stamp and uploaded to HQ for later (or in some cases real time) analysis.

A good explanation of this kind of system is on AEBI Schmidt's website where it describes it's "autologic" product:

**"Simple and reliable spreading:** *Autologic is an easy to use, automatic spreading system with routing. The GPS navigation guides the driver along the route and the spreading settings occur automatically. This enables the driver to fully concentrate on the traffic without being distracted by the spreading process.*

**Flexible use:** *The route is driven once to collect the settings for spreading. The route data is fed into the CL control panel. At the start of the following spreading application, the driver selects the route and follows the directions. Autologic ensures exact spreading fully automatically: Dosage, spreading width, symmetry etc. are exactly matched to the route. This enables the optimal spreading even of complex routes with roundabouts or stretches of motorway. The lack of route knowledge no longer poses a problem when deploying staff.*

**Route Creator PC application:** *Using the PC application, Route Creator, routes and spreader settings can be altered without having to drive the route again. This is particularly useful during heavy snowfall when higher dosage levels are required. With Route Creator, spreader settings are easily adjusted and can be saved as an alternative route."*

Schmidt's software to edit the route and input it back into the truck is a convenient and powerful feature.

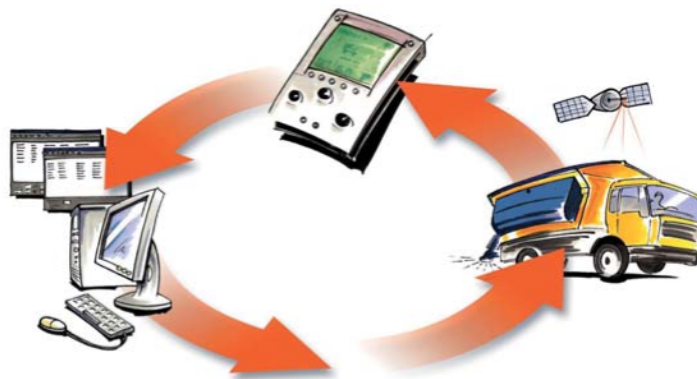

**Figure 20:** AEBI Schmidt's Autologic system

It is possible to trigger the spread controller using a combination of sensors. Thus, the vehicle speed, surface temperature, and location can all be used to regulate the distribution of granular material. Figure 20 shows the PDA controller for Autologic, which has ground speed and GPS automation.

## VIII. Level Three: Automatic Controller With Remote Control and GPS (and/or sensors)

Most spread controllers have a communications module by which users can signal the controller to perform selected actions. The majority of them are used for data downloads or firmware updates. However, it is feasible that a central supervisor could signal the spread controller in each truck individually or collectively to change chemical treatment rates or material remotely from their computer device (desktop, tablet, smart phone, etc.). This type of system can handle another level of sophistication in reaction to a storm. A few examples are:

1. The weather or the forecast can change during the route and amounts can be adjusted accordingly during the truck's route.
2. Traffic and/or public safety information can be used to adjust patterns and amounts.
3. Fleet-wide control of resources from a central location can be achieved.

Figure 21 illustrates the basic difference between levels 2 and 3.

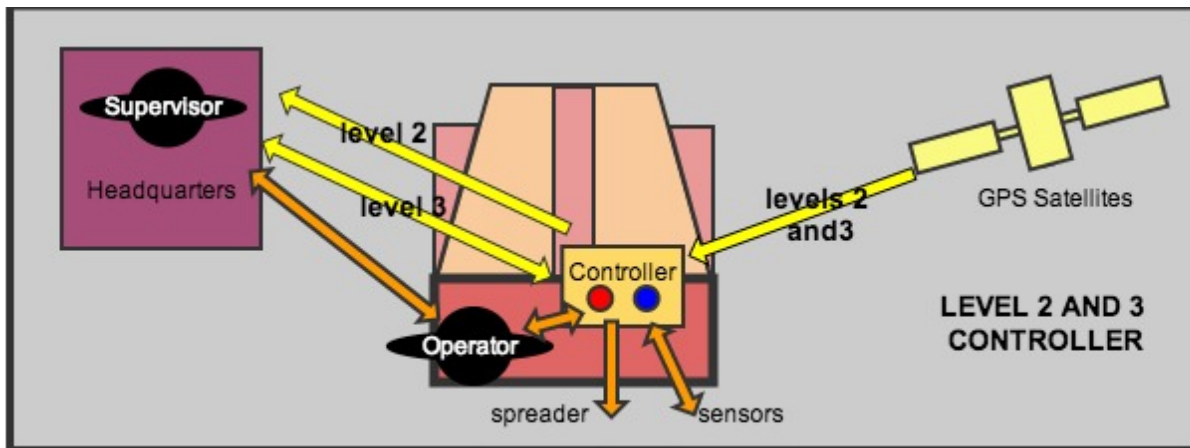

**Figure 21: Level 2 and level 3 control function.** The only difference between levels 2 and 3 is that the controller to headquarters communication is two-way in level 3.

The communication from headquarters to controller is a current area of research and testing. These authors did not find a commercially available system with this capability though in principle the technology exists and some manufacturers are developing products with this capability in mind (see the caption of Table 7)



## A. Software and System Integration:

The software used to program the spread controllers as part of an automatic spreading system is usually proprietary to each vendor. Vendors have advanced spread controllers that allow for upload of firmware changes and updates. Often this is accomplished with a mobile laptop or jump drive or even a unique handheld device. Several of these methods are discussed below.

Vendors use the following methods to update or modify their firmware to correct software bugs, or provide new additions or features. Also, this method can be used to turn on additional features that their customers subsequently acquire or purchase.

- (4) *Interactive control.* This feature allows for data download control. In other words, the operator can interrogate the unit for maintenance indicators, history, threshold values, or others.
- (5) *Remote download.* Most vendors' advanced spread controllers collect usage data and getting the data off the truck always presents a challenge. The remote download capability can be executed wirelessly (wi-fi, cell modem, blue tooth, etc.) or by visiting the vehicle with a laptop, jump drive, or other device.
- (6) *Command/response.* A method of communication, the command/response method provides an additional level of control and added efficiency by requiring the spread controller to only provide what is asked for with regards to data download or information.
- (7) *One-way communication.* This method is the most common. When prompted, the read controller provides a data dump of all information to a receiving unit.

**System integration** is a particularly challenging aspect of automatic spreading. This involves matching the components of an automatic spreading system with the unique requirements of individual users. The block diagram in Figure 22 illustrates a typical auto-spreading system that is available today. The graphic provided in Figure 22 was provided by Monroe Trucking and is part of their training and marketing program.

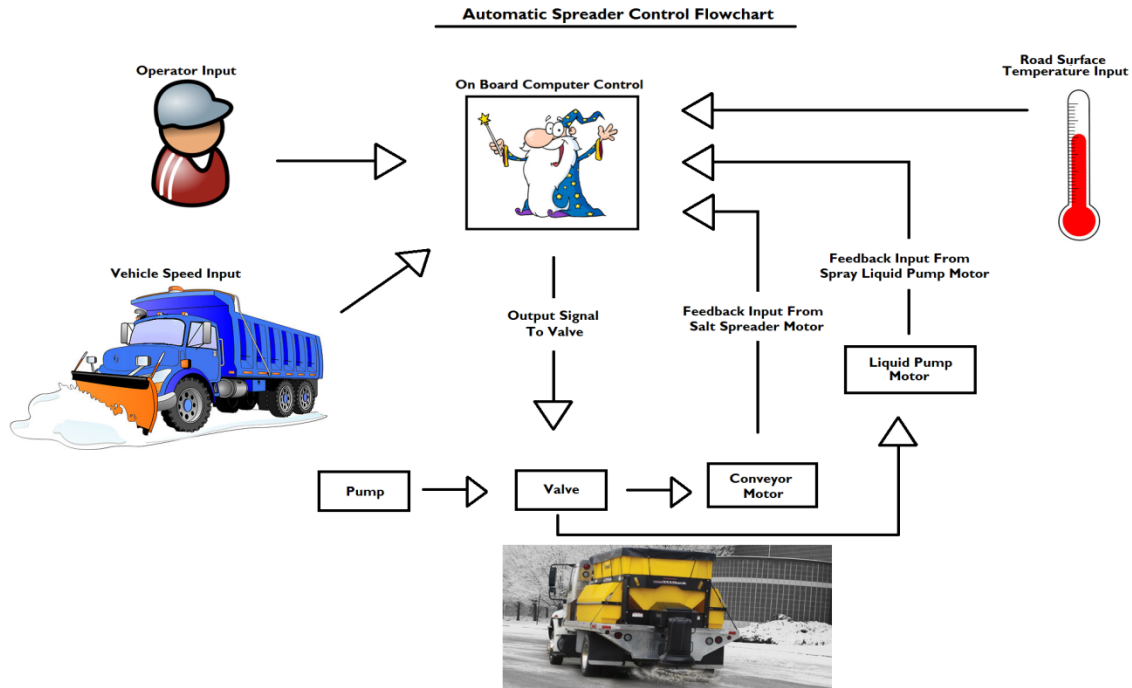

**Figure 22: Monroe Trucking Training Diagram of Auto-Spreading**

This diagrams the most popular type of automation - the closed-loop, ground-speed control. Most controller manufacturers offer this type of system.

An example of Automatic Spreading Features from Cirus Controls is shown in Table 9. This list of features illustrates the number of options that are included in configuring the system integration characteristics of an automatic spreading system. Note that automatic spreading is called “prescription spreading”.

Feature & Capability	Description & Application
Product Summary	8 channel, ground speed oriented, open/closed loop controller with data logging and optional wireless data transfer; prescription spreading using live road temperature data and/or by programmed rates
Product Application	Auger/conveyor, spinner, pre-wet and anti-icing (3 booms x 2 tiers); Single controller for tow plow truck and trailer
Spreading Precision	Industry-leading spreading precision in closed loop and open loop operation
Compensation for Single or Multiple Lane Width Settings	Area spreading in lbs/gal per lane mile (auto adjusts auger rate for > 1 lane spreading); Linear spreading in lbs/gal per mile (operator controls spinner)

Feature & Capability	Description & Application
Spreading Rate Definitions	Programmable application rates for granular, pre-wet and anti-icing; 10 types for granular, 10 types for pre-wet, 10 types for anti-ice
Temperature-Linked Spreading Prescriptions	Temp Response™ integrates road temperature sensor, controlling granular and liquid application automatically
Load & Rate Calculator & Material Remaining	Calculates requirements for each route (miles) and automatically sets system rates; Auto mode includes indication for miles, tons, gallons and % remaining
Closed Loop Proportional Gate Control	Control of optional closed loop hydraulic gate height and conveyor speed
English & Metric Units Standard	System operates in English or metric units
Data Logging by Material Name for Billing Purposes	Select specific application rate definitions and related data logging for use on specific roads (i.e. state vs. county vs. city roads)
Storm & Season Totals	System logs application amounts by rate definition for the storm and the season (storm total is operator resettable)
System Set-Up Wizard	On-screen, step-by-step programming and troubleshooting
On-Screen Diagnostics & Help Menu	System diagnostics available on screen for settings, software, memory, GPS, distance meter; Easy-to-follow instructions for use of all parameters shown in “help menu”
Blast & Pass (Pause)	Blast is programmable (on/off, timed, momentary); Pass (pause spreading temporarily); Remote blast and remote pass accessible
Signal Communications	Multiple frequency settings for valve compatibility; Multiplex / CAN Bus Communication
Power Safety	Power Safe™ signals prevent random grounds powering any hydraulics system attached; Channel Safe™ detects and protects against open or short circuits on hydraulic drive channels; Minimum 11 Volts DC; Maximum 15 Volts DC
System Display Options	10.25” color TFT touch screen; 32 lines, 40 characters/line
System Mounting	Standalone or dash mount for display

Feature & Capability	Description & Application
Warning Indicators	Visible (on display) and audible (buzzer)
Optional Equipment	GPS antenna; Road and air temperature sensor; Drive by Download™ system; gate height sensor, gate height position, hopper level

**Table 9: An Example of Automatic Spreading Capability from Cirus Control.**  
In terms of automation, this table represents the closed-loop, ground-speed and the pavement temperature control options.

## IX. Summary of Levels of Automation:



**Figure 23: A typical controller setup used by Michigan DOT.** Photo courtesy of Mark Crouch, MDOT

This guide has given a basic explanation of automation as applied to salt spreaders used for winter maintenance. The degree of automation was divided into different levels and sub-levels

to allow the snow fighter to identify the current level of automation and to identify the next step in the automation sequence (see tables 7, 8 and 10.) The following Table 10 summarizes the capabilities of the different levels of automation.

Level	0	1	1	1	2	3
Description of controller	Manual	Ground speed open-loop	Ground speed closed-loop	Pavement temperature sensor	GPS record a route	GPS remote control
Ability to react to changes in vehicle speed	no	yes	yes	no	no	no
Ability to react to changes in wear and tear of hydraulics	no	no	yes	no	no	no
Ability to react to changing local weather conditions	no	no	no	yes	no	no
Ability to react to changing regional weather conditions	no	no	no	no	no	yes
Ability to react to intersections, changing number of lanes, etc.	no	no	no	no	yes	yes
Does this feature save salt?	no	no	yes	no	yes	yes
Does this feature improve the accuracy of salt placement?	no	yes somewhat	yes	yes	yes	yes
Ability to react to public safety emergencies	no	no	no	no	no	yes
Cost	\$	\$	\$\$	\$\$	\$\$\$	\$\$\$

**Table 10: Features vs. Level of Automation:** Note that a system with closed-loop, ground-speed control, pavement temperature sensor control, GPS record a route and GPS remote control would have all the features in this table.

## Guide #3: Challenges and Currently Available Systems

### X. Introduction to the Systems:

Guide #3 will do three things: discuss challenges in the development of an automated spreading system, survey and compare existing automated spreader systems, and present some ideas on testing automated systems. *Testing these automated systems is a very important step in their acceptance by the consuming transportation agencies and the lack of testing in the United States can be seen as a glaring challenge.* There are a number of fully automated systems available (Level 3 automation – see Guide #2), with foreign manufacturers leading the way. The challenges section begins with a short discussion of agricultural technologies as they face many of the same hurdles salt spreading systems do.

### XI. Agricultural Technologies:

In principle the use of GPS and automated technologies could be easier in the field of agriculture than in winter maintenance because the speeds used by agricultural spreaders are slower than salt spreaders and the conditions affecting the need to change spreading rates and patterns changes are slower (e.g. soil composition.) Of course there are inherent differences as well. Farming can make better use of stationary sensors for input and whereas the driving force behind automation in farming is increased yield, the objective of winter maintenance is increased safety.

In the agricultural field the use of GPS and other automation technologies to help plan and implement crop maintenance is called “precision agriculture”. The following is a typical list of benefits taken from a machine testing company, “Accu-Spread.” They are a typical set of claims about precision agriculture.

“The primary benefits of having an Accu-Spread (see bibliography) tested machine are to:

- minimize environmental damage through over application of nutrients
- ensure the appropriate amount of fertilizer is evenly applied
- provide operators with information about the performance of their machines
- provide farmer customers with confidence that spreader operators are accurately applying the **right amount of fertilizer in the right place**
- improve efficiency for spreader operators
- improve operating standards in the industry
- provide operators with a risk management tool in the form of an independent test of the performance of their machine.”

Real Time Kinematics (RTK) denotes highly precise satellite positioning (centimeter-level accuracy). Case, Inc. manufactures some very advanced RTK agricultural products. The following are the claims they make about their Patriot Sprayers:

- **“AccuBoom Automatic Boom Section Control** – Automatically turn off appropriate boom sections when the sprayer enters an area where product has already been applied, and automatically turn them back on when leaving a pre-applied area. When a Patriot sprayer enters an internally marked area like a waterway, you can set AccuBoom to automatically turn off sections, and you can automatically turn them back on when the sprayer leaves this boundary.
- **As-Applied Mapping** – Automatically record and map where you’ve applied inputs. In addition, track products used and their attributes, such as mixture, manufacturer information, EPA numbers and more, to simplify and improve record keeping and input tracking.
- **Variable Rate Control** – Adjust Patriot application rates manually or by using a prescription created with AFS software. Use prescription variable-rate application maps to apply more or less chemical or fertilizer to areas as needed to improve yields and save money with a more precise application.”

Probably the most studied and challenging metric in the quest to automate the spreading functions of the agricultural (and winter maintenance) spreaders is accuracy coupled with speed of the vehicle. The bibliography cites some references about how the speed of the vehicle affects the accuracy of the spreading. Though still below salt spreading speeds, the agricultural industry claims to have achieved speeds (Trimble-Straight Talk) of 14 mph (too slow for salt) with accuracy of 1 inch (too much for salt).

Agricultural systems make a compelling comparison to winter-maintenance, salt-spreading systems. They have encountered and solved/struggled with many of the same problems as the salt spreaders have. These agricultural technologies will be a fruitful partner in the upcoming challenges of developing a practical and affordable auto-spreading system for winter maintenance applications.

## XII. Challenges of Automation:

**A. Accuracy of spreading:** The best study of the accuracy and responsiveness of GPS-controlled spreaders is by Bo Sommer in Denmark. Four different controllers were studied: Nido, Falköping, Epoke and Küpper Weisser. In terms of accuracy, the following scale was used to evaluate programmed changes in the spread pattern or rate.

Color	Definition
Fine	A fine start or stop is when the change occurs within 5 meters from the specified reference point. 5 meters are equal to 0,3 second driving at 60 km/h
Acceptable	A just acceptable result will be when a change occur with a precision of 8 meters from the specified point equal to 0,5 second at 60 km/h
Unacceptable	An unacceptable result is a precision of 8-20 meters corresponding to 0,5-1,2 second at 60 km/h
Missed change	A missed change is when it takes place more than 20 meter away form the reference point or does not take place at all

**Table 11:** Scale for measuring accuracy of spread changes used by Sommer.

The test course was run at 30km/hr (19 mi/hr) and at 50km/hr (31 mi/hr). Of course better accuracy was achieved at 30km/hr but only slightly better. The following table summarizes the results.

	Fine	Acceptable	Unacceptable	Missed Change
Epoke	14	4	2	
Nido	9	4	8	1
Falköping	11	2	2	6
Küpper Weisser	3	2	5	14

**Table 12:** This is the number of changes in each rating category.

This study was conducted 3 years ago and was not meant to be a competition. Overall, 56% of the changes were fine or acceptable accuracy considering all manufacturers.

Paraphrasing from the conclusion of an article in 2013 (Möller, most of which is in Swedish):

“On the whole, spreading salt with GPS control gave about the same results as with the driver making the changes of the salt spreader. On average the measured amounts of salt corresponded, in most cases, fairly well with the intended. At the same time, GPS control of the salt spreader means that the quality of the salting can be improved because the salt, to a larger extent, is spread only where it is needed. GPS control also has a positive effect on road safety and the working environment for the driver because he does not need to change the spreader adjustments but can concentrate on driving instead.”

**B. Ease of editing the route:** With the recorded-route-GPS-type of automation, the software in the truck used to record the route varies greatly between manufacturers. One feature that



seems very valuable is the ability to edit the route/data on a remote computer as opposed to solely on the controller screen in the truck. Some manufacturers offer this feature.

**C. Data Gathering:** The above-mentioned study by Sommer also measured the accuracy of the data gathered by the four manufacturers and found the data gathered to be accurate for all four. The bigger challenges with data gathering are:

4. The ease with which the data is gathered.
5. The software available to manipulate the data.
6. Effectively using this data for future planning, cost cutting and level of service evaluation.

The first two considerations vary with each manufacturer and the software needs to be demonstrated to the snow fighters by the manufacturers. The third consideration has to be evaluated by each group and a plan needs to be in place to use the data effectively.

**D. CAN bus utilization:** The more the spreader integrates with the CAN bus the more possibilities for upgrading and adding sensors, etc. Dicky-John's Flex4 design claims "This customizable ice control system uses a CAN bus design that offers a customizable platform for today's demand and expansion for future capabilities." Another spreader from Ireland, the Romaquip's 6 x 4 Ultima Salt Spreader, claims "Bespoke CAN bus electronic control with data Logging, RS232, 2 x emagrecer rapidamente CAN bus & USB Real time tracking, logging and remote control capabilities."

**E. Cost considerations:** In addition to the usual question of initial unit price, there are some additional things to consider when deciding on an automated spreader. For instance:

- How much salt will it save?
- Will it increase or decrease staff hours?
- What are installation costs?
- What are training costs?
- What additional hardware is needed (sensors, computers, etc.)?

### **XIII. Sources of Total Systems**

All existing systems fall into three categories of automation: (1) Systems triggered by on-vehicle sensors, (2) GPS-recorded-route systems, (3) Remote-control systems.

**A. Vehicle sensors:** Systems triggered by on-vehicle sensors operate similarly to the ground speed spread open- or closed-loop control systems, where the ground speed controls the amount of material distributed to the roadway. This type of automatic control has been used for years. Another example uses an onboard sensor such as a pavement temperature sensor to monitor and adjust the spread rate based on temperature data. As the road surface temperature changes the material distribution rate changes appropriately (see Figure 24).

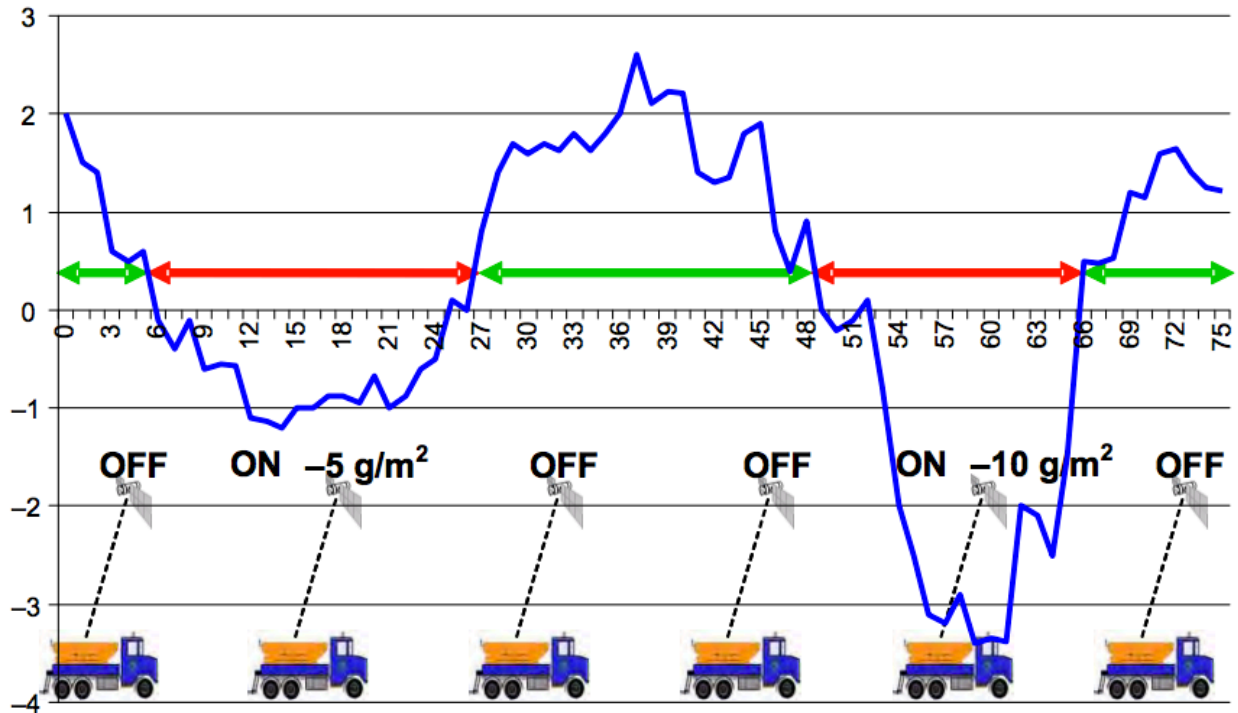

**Figure 24.** From Knudsen and Sommer, “Global Positioning System–Controlled Salt Spreading: From Idea to Implementation”. This figure shows how a pavement temperature sensor can trigger a salt dosage change. The pavement temperature (in Celsius) is blue.

**B. Recorded Route Systems:** Systems automated by programmed or recorded route plans use a GPS receiver or similar location sensor to execute a programmed route. As the vehicle travels the route, the amount of material spread by the system is controlled according to the vehicle’s location or position relative to the assigned route. The routes can be previously recorded while driving the route or can be programmed using the spread controller firmware. The program may be as simple as mandating a particular spread rate for that route or more sophisticated, recognizing when the vehicle is approaching a trouble spot (bridge, intersection, and/or hill) and adjusting the amount of material accordingly.

**C. Remote Control:** The third type or level of automation involves remote control from a central dispatch or headquarters terminal. A supervisor from headquarters using wireless connections to the trucks in the field can adjust spread rates. In this case, changing weather conditions that are known at headquarters can be used to adjust rates and procedures for plows in the field in real time. Though this would be a valuable and feasible type of automated spreader, the snow and ice removal industry has not yet fielded a remote controlled automated spreading system.

**D. The Systems:** The following is a comprehensive list of fully automated systems. Websites for the manufactures are given here and in the bibliography. A summary of the different types of systems is given below in Table 13.

## AEBI Schmidt

<http://www.aebi-schmidt.com/en/products/de-icing>

Their system, named “Thermologic,” senses pavement temperature on board the snow plow and adjusts the amount spread based on this parameter; it has the capability to adjust the amount up to 5 times each minute. Below are pictures of the in-vehicle control box (Figure 25) and rear view of the spreader (Figure 26).



Figure 25: AEBI Schmidt's controller



**Figure 26: Schmidt's Vbox spreader.**

When Schmidt's "Autologic" system is added to "Thermologic" it is an example of the most automated system available on the market. Autologic is a GPS-based recorded route system where the driver pre-programs spread amounts and widths, etc. along a prescribed route and then the onboard logic system remembers the route, guides the driver and delivers the predetermined amount of salt.

Other features:

- The system is suitable for every spreading and spraying scenario (dry, pre-wetted, spraying and spraying with salt).
- The digital, fast response system adjusts the dosage more frequently and faster than manually possible.
- There is a substantial reduction in the amount of spreading material used (15%).

## Giletta

<http://www.giletta.com/prodotti.aspx?l=ing&s=giletta&b=Spreaders&M=The%20Range>

Giletta offers a recorded route product called “Ecosat10 Control System”. The vehicle drives a route during a snowstorm and the spread controller records that route by location using a GPS receiver. The vehicle operator can then drive the same route and distribute material in accordance with the recorded route feature. Figures 27 and 28 are photos of the control box and the spreader.



Figure 27: Giletta's controller



Figure 28: Giletta's spreader

## Monroe

[www.monroetruck.com](http://www.monroetruck.com)

Monroe has the Monroe MC-840™, an automated spreader that can adjust spread rate based on road temperature. It has the ability to manage the spreader, spinner, pre-wet and anti-ice controls as the system monitors road surface temperature. See the following web sites for additional information. Figure 29 provides a photo of the Monroe pre-wet spreader system.

<http://www.monroetruck.com/Pdf/Hydraulics/840%20Brochure.pdf>

<http://www.monroetruck.com/Pdf/SpreaderCtrls.pdf>



Figure 29: Monroe's pre-wet spreader

## Küpper-Weisser

<http://www.kuepper-weisser.de>

Figure 30 provides a photo of the Küpper-Weisser IMS spreader.



Figure 30: The Küpper-Weisser IMS spreader

This German firm produces two kinds of automated systems. They offer a very advanced controller, the Vpad, which can handle both the sensor-based automation with an infrared pavement temperature sensor and the recorded route type with its GPS system. See Figures 31 and 32.



**Figure 31: The Küpper-Weisser Vpad**

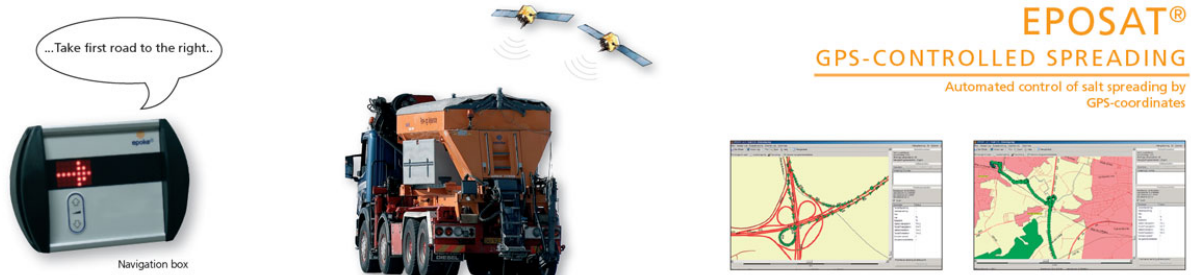

**Figure 32: Küpper-Weisser's infrared temperature sensor**

## Epoke

<http://www.scarab-epoke.co.uk/eposat.html>

Epoke's offering in the automated spreading market is called "EpoSat® - Automated Control of Salt Spreading". This is a recorded-route-type of spreader that has some interesting software features. From the company literature, "The operations manager may use the EpoSat® software to edit routes and change settings. The software allows cutting, copying, insertion of speech messages and addition of 'way points,' whereby a route may be expanded/changed without having to perform a new route recording. The recorded routes are then transferred to the spreader computer again, and may then be used by the driver for automated spreading." The promo photo of the EpoSat follows. See figure 33.



**Figure 33: Epoke's recorded route spreader system**

The following two photos (Figure 34) from Epoke's website give an illustration of the intended capability of the spread controller. The first photo is without GPS-controlled spreading and the second is with GPS-controlled spreading.



**Figure 34: Width controlled spreading from Epoke**



### Multidrive from the United Kingdom

<http://www.multidrivetractors.co.uk/>

Multidrive has a controller called NL 7 which has automation to turn the controller on or off based on field boundaries and/or previously applied areas. It is called AutoSwath™. It has automatic conveyor control when crossing a field boundary or driving across an area that has already been applied. The AutoSwath™ turns the conveyor or boom section(s) on or off based on field boundaries or prescription-mapped areas, as well as previously applied areas of the field. AutoSwath™ functionality is standard on the NL 7 for granular usage. This feature is also available for liquid applications. See figure 35.



Figure 35: Multidrive's NL7 controller

<http://www.multidrivetractors.co.uk/nl7%20controller.pdf>

**Cirus Controls:**

<http://www.ciruscontrols.com/>

Cirus Controls has an automated spreader named SpreadSmartRx™ which integrates a road temperature sensor (Temp Response™). This system can control granular and liquid application automatically. See figure 36.



**Figure 36: Cirus Control’s controller**

**Nido from Denmark**

<http://www.svenningsens.dk/>

Nido has a product called Thermologic that constantly measures the road temperature via an infrared sensor behind the spreader. This automatically adjusts the spread rate based on the pavement temperature. See figure 37.



**Figure 37: Nido’s spreader system**

**Falköping from Sweden**

[www.friggeraker.se](http://www.friggeraker.se) & <http://www.gincor.com>

Falköping products are distributed in North America by GinCor Industries. Falköping has a pavement temperature sensor and a “record a route” automated systems. See Figures 38 & 39.



**Figure 38: A pair of Falköping Automatic Spreader Systems**



**Figure 39: Falköping’s hot water/sand spreader for extremely cold temperatures.**

**Bosch Rexroth from Canada**

<http://www.boschrexroth.ca/>

Bosch Rexroth have an integrated controller called the CS 550/150 which can adjust application rates based on temperature sensors plugged into the controller. Figure 40 shows this controller.



**Figure 40: the Rexroth Model CS 550/150.**

Table 13 summarizes the available automation features by manufacturer. Notice there are no “remote control” spreaders. Also, whereas some manufacturers offer the “triggered by on-vehicle sensors” and not the GPS/recorded route, others offer the reverse.

Manufacturer	Triggered by on-vehicle sensors*	GPS/recorded route	Remote Control
<b>AEBI Schmidt</b>	Yes	Yes	No
<b>Giletta</b>	No	Yes	No
<b>Monroe</b>	Yes	No	No
<b>Küpper-Weisser</b>	Yes	Yes	No
<b>Epoke</b>	Yes	Yes	No
<b>Multidrive</b>	No	Yes	No
<b>Cirus Controls</b>	Yes	No	No
<b>Nido</b>	Yes	Yes	No
<b>Falköping</b>	Yes	Yes	No
<b>Bosch Rexroth</b>	Yes	No	No

**Table 13: Current available fully automated spreaders.**

\* This category refers to sensors in addition to the ground speed control which is offered by almost all manufacturers.

## XIV. Conclusion and Testing

There are at least ten manufacturers producing automated salt spreaders. The concept and the application are well on their way to mainstream deployment. However, it should also be noted that some of those systems do not appear to perform completely as “advertised” as the field test results from the Denmark study (Sommer, B.) indicate. Another interesting fact is that no manufacturer has a “remote control” auto-spreader on the market (one that could control the spread rates and spread configurations of trucks in real time out in the field from headquarters).

Table 14 examines the current state of the art for automated spreaders in today’s market. Several vendors have advanced spreading systems in development and were unable to share their proprietary technology at this time. Several configurations exist in some form already and are available in the market place.

Priority Level	Capabilities	Degree of Attainment
<b>First</b>	Automated setting of an average application rate	Well established
	Automated recording and archiving of what material was applied where, and when	Well established
<b>Second</b>	Automated variation from average application rate as a function of road surface temperature	Well established
	Automated variation in spread pattern as a function of location	Provided but some difficulties in attaining desired performance
	Automated variation from average application rate as a function of traffic conditions	Not yet available
<b>Third</b>	Automated variation from average application rate as a function of location	Well established
	Automated variation from average application rate as a function of current weather conditions	Not yet available
	Automated variation from average application rate as a function of forecast weather conditions	Not yet available

**Table 14: Current Availability of Desired Capabilities**

**With only two available studies as to the accuracy of GPS spreading (Sommer and Möller) and no studies in the United States, the need for further studies is indicated. Probably the fastest approach to testing these GPS-automated systems is to use one or more of the European products and test them on one of the domestic test tracks available.** Though systems manufactured by companies with automated spreader systems are in use within the United States, these authors were unable to find one of the European GPS-controlled spreaders in use in the United States. Further study would require renting one or interesting the manufacturer in a study.

**In addition there are a number of the pavement temperature automated systems in use in the United States. Testing the accuracy, the salt-saving potential and the level of service of these systems would be a valuable research project.**

## Appendices:

### XV. Bibliography

#### A. Basic information about spreaders:

Newspaper article

<http://www.roadsbridges.com/ready-steady-spread>

Clear Roads article about ground speed controllers and their effectiveness.

<http://www.clearroads.org/downloads/ready-steady-spread.pdf>

The Salt Institute Snowfighter's Handbook

<http://www.saltinstitute.org/content/download/484/2996>

From the Illinois DOT:

[www.dot.state.il.us/blr/p013.pdf](http://www.dot.state.il.us/blr/p013.pdf)

and

[www.dot.state.il.us/blr/L026%20The%20Snowfighters%20Handbook.pdf](http://www.dot.state.il.us/blr/L026%20The%20Snowfighters%20Handbook.pdf)

From FHWA:

[www.fhwa.dot.gov/reports/mopeap/eapcov.htm](http://www.fhwa.dot.gov/reports/mopeap/eapcov.htm)

MassDOT Snow and Ice Program

[http://www.mhd.state.ma.us/downloads/projDev/ESPR\\_2012/EnvironStatus\\_PlanningRpt\\_0212.pdf](http://www.mhd.state.ma.us/downloads/projDev/ESPR_2012/EnvironStatus_PlanningRpt_0212.pdf)

Michigan DOT:

[http://www.michigan.gov/documents/stormwatermgt/MDOT\\_MS4\\_Winter\\_Road\\_Maintenance\\_208467\\_7.pdf](http://www.michigan.gov/documents/stormwatermgt/MDOT_MS4_Winter_Road_Maintenance_208467_7.pdf)

From the Maine DOT. A bit dated. The technology has certainly improved since then, but a good place to begin.

<http://www.maine.gov/mdot/tr/documents/pdf/report0501final.pdf>

Dated 2008 from the Idaho DOT. A good slide show about the basics of spreaders and their components.

<http://pnsassociation.org/wp-content/uploads/Idaho.pdf>

Calibration of spreaders:

<http://www.clearroads.org/research-projects/05-02calibration.html>

## **B. Best practices and emerging technologies:**

Thompson, et al. Survey for the Development of a Totally Automated Spreading System” by Thompson Engineering for Clear Roads, 2013

CTC and Associates report for Clear Roads investigating level of service definitions with input from 16 different states, counties and Canadian provinces.

<http://www.clearroads.org/downloads/tsrlevelsofservice.pdf>

A 2008 Winter Maintenance Policy from Finland. Level of service concerns are illustrated and discussed.

[http://alk.tiehallinto.fi/julkaisut/pdf2/1000199e-v-08winter\\_main\\_policy.pdf](http://alk.tiehallinto.fi/julkaisut/pdf2/1000199e-v-08winter_main_policy.pdf)

2013 article about using Cirus Controls spread controllers on Iowa DOT vehicles and saving 10% of the salt used.

[http://www.ciruscontrols.com/wp-content/uploads/2013/02/iowa\\_DOT\\_case\\_study.pdf](http://www.ciruscontrols.com/wp-content/uploads/2013/02/iowa_DOT_case_study.pdf)

Burkheimer, D. Iowa DOT, “Iowa Department of Transportation Snow and Ice Operations” A very informative slide show with many innovations illustrated from 2009. Many “handmade” examples shown here.

<http://pnsassociation.org/wp-content/uploads/IowaDOT.pdf>

Mobile Equipment News, “Salt or Sand Spreader Power”. This is an article that explains the different ways to power the salt spreader.

<http://mobileequipmentnews.com/salt-or-sand-spreader-power/>

Ketcham, S., L.D., Minsk, R. R. Blackburn, and E.J. Fleege, “Manual of Practice for an Effective Anti-Icing Program,” Report No. FHWA-RD-95-202, Federal Highway Administration, Washington D.C., June 1996. Available on-line at:

<http://www.fhwa.dot.gov/reports/mopeap/eapcov.htm>

Sommer, B. “TESTING OF GPS CONTROLLED SALT SPREADING AND DATA COLLECTION AT THE BYGHOLM CENTRE” This Danish study done in 2010 is the best published study on the accuracy of GPS recorded route type spreaders. Four manufacturers products were tested; Nido, Falköping, Küpper-Weisser and Epoke.

<http://www.nvfnorden.org/lisalib/getfile.aspx?itemid=4593>

Global Positioning System–Controlled Salt Spreading , From Idea to Implementation, by FREDDY KNUDSEN and BO SOMMER from the Danish Road Directorate in the proceedings from the Seventh International Symposium on Snow Removal and Ice Control Technology, June 16–19, 2008

<http://onlinepubs.trb.org/onlinepubs/circulars/ec126.pdf>



Möller, S. "GPS controlled salt spreading. Trial on a test track". A 2013 article (in Swedish) about accuracy of GPS controlled salt spreading.

<http://www.vti.se/en/publications/pdf/gps-controlled-salt-spreading-trial-on-a-test-track.pdf>

An article from 2012 describes a system that claims, "Our new onboard unit allows us to use GPS navigation signals, augmented by EGNOS and EDAS, to track our salt-spreading vehicles at all times and to control the amount of salt being applied in a very precise way, based on real weather conditions and specific road morphology."

<http://www.egnos-portal.eu/news/precision-salt-spreading-demonstrated-prague>

From the Michigan DOT

[http://www.mhd.state.ma.us/downloads/projDev/ESPR\\_2012/EnvironStatus\\_PlanningRpt\\_0212.pdf](http://www.mhd.state.ma.us/downloads/projDev/ESPR_2012/EnvironStatus_PlanningRpt_0212.pdf)

The Nevada DOT has a great introduction to emerging technologies

[www.nevadaDOT.com](http://www.nevadaDOT.com)

From Vaisalla, here is an overview of an early AVL semi-automated spreader system in use in Franklin County, OH.

[http://www.vaisala.com/Vaisala%20Documents/Success%20Stories/RDS\\_Franklin%20County%20COMBAT\\_Surface%20Patrol.pdf](http://www.vaisala.com/Vaisala%20Documents/Success%20Stories/RDS_Franklin%20County%20COMBAT_Surface%20Patrol.pdf)

The Society of Automobile Engineers has produced recommended practices for temperature sensors. This SAE Aerospace Recommended Practice (ARP) covers the requirements for a combined Mobile Digital Infrared Pavement Surface, Ambient Air, and Dew Point Temperature Sensing System (referred to as the system). The system monitors real-time surface, air and dew point temperatures.

<http://standards.sae.org/arp5623/>

The Missouri DOT has researched a mirror-mounted pavement temperature sensor.

<http://library.modot.mo.gov/RDT/reports/TA97010/RDT99007.pdf>

New research from Norway about hot water and sand/salt mixtures.

<http://www.clearroads.org/downloads/tsrsnowremovcoldtemps.pdf>

A study using a Cirus Controls automated spreader to investigating savings due to automating spread rates: "Spreader Control Units with GPS Tracking" by Paul Wittau, Zach Zaranko, Greg Annis, University of Iowa

A study investigating Cargill's "Safelane" surface overlay product, "Winter Highway Maintenance, Using Safelane", by Mark Gansen, Victoria Roemig, & Bryan Horesowsky, University of Iowa

This study measures the accuracy of a salt measuring device, the SOBO-20, that measures salt concentration on pavement.

<http://docs.trb.org/prp/13-2606.pdf>

Salt on pavement measuring device prototype from 2002 that uses the spray from the tires.

[http://www.uvm.edu/~transctr/pdf/netc/netcr17\\_97-1.pdf](http://www.uvm.edu/~transctr/pdf/netc/netcr17_97-1.pdf)

### **C. Workforce Concerns**

Blackburn, R.R., K. M. Bauer, D.E. Amsler Sr., S.E. Boselly, and A.D. McElroy, "Snow and Ice Control: Guidelines for Materials and Methods," NCHRP Report 526, Transportation Research Board, Washington D.C., 2004. [http://onlinepubs.trb.org/onlinepubs/nchrp/nchrp\\_rpt\\_526.pdf](http://onlinepubs.trb.org/onlinepubs/nchrp/nchrp_rpt_526.pdf)

Cronin, B., L. Anderson, B. Heinen, C. B. Cronin, D. Fien-Helfman, and M. Venner, "Strategies to Attract and Retain a Transportation Workforce," NCHRP Report 685, Transportation Research Board, Washington D.C., 2011.

[http://onlinepubs.trb.org/onlinepubs/nchrp/nchrp\\_rpt\\_685.pdf](http://onlinepubs.trb.org/onlinepubs/nchrp/nchrp_rpt_685.pdf)

Spy Pond Partners, B. Martin, ERS Associates, and Randolph Morgan Consulting, "Tools to Aid State DOTs in Responding to Workforce Challenges," NCHRP Report 636, Transportation Research Board, Washington D.C., 2009.

[http://onlinepubs.trb.org/onlinepubs/nchrp/nchrp\\_rpt\\_636.pdf](http://onlinepubs.trb.org/onlinepubs/nchrp/nchrp_rpt_636.pdf)

### **D. Agricultural Technologies**

Accu-Spread: Advantages of precision agriculture are discussed here:

<http://www.afsa.net.au/index.php?action=content&page=12>

Case: There are some very advanced systems like this one from Case:

[http://www.caseih.com/en\\_us/AFS/Pages/Section-Rate-Control.aspx](http://www.caseih.com/en_us/AFS/Pages/Section-Rate-Control.aspx)

University of Minnesota: A useful collection of a variety of precision farming links are here:

<http://www.precision.agri.umn.edu/links.shtml>

Trimble: An overview paper on precision farming systems:

[http://www.trimble.com/pdf/AG\\_RTK%20BSNetworks\\_WP\\_0806.pdf](http://www.trimble.com/pdf/AG_RTK%20BSNetworks_WP_0806.pdf)

AutoFarm: Great results are promised, but getting details is not particularly easy. For example, this is a typical site:

<http://www.gpsfarm.com/>

University of Missouri-Extension: The issue of accuracy and rate of response is critical. This paper touches on it:  
<https://mospace.umsystem.edu/xmlui/bitstream/handle/10355/9468/PrecisionAgricultureGPS.pdf?sequence=3>

Though this paper is not specifically about speed, the first paper indicates the sort of lag that can occur.  
<http://www.gps.gov/applications/agriculture/>

GPSFARM: This article provides some low speed info – they can go as slow as 0.01 mph which is probably not very helpful for salt spreading, but it is a benchmark:  
<http://www.gpsfarm.com/ProductSolutions/RTKAutoSteer/tabid/100/Default.aspx>

Raven Conrollers: This Raven controller promises best-in-class operating speeds, but does not say what those are!  
<http://www.ravenprecision.com/sitecore/content/RavenSite/Products/Guidance%20and%20Steering/SmarTrax%20RTK.aspx>

Trimble: Here is an article that suggests speeds of 14 mph are feasible with this sort of accuracy:  
[http://trl.trimble.com/docushare/dsweb/Get/Document-224052/StraightTalk\\_Spring%202005.pdf](http://trl.trimble.com/docushare/dsweb/Get/Document-224052/StraightTalk_Spring%202005.pdf)

## **E. Environmental Concerns**

Government of British Columbia  
<http://www.env.gov.bc.ca/wat/wq/bmps/roadsalt.html>

A report on “Strategic Planning for Reduced Salt Usage”, was prepared by Parsons Brinckerhoff for The National Cooperative Highway Research Program Transportation Research Council National Research Council in 2007.  
[http://onlinepubs.trb.org/onlinepubs/archive/notesdocs/25-25\(29\)\\_fr.pdf](http://onlinepubs.trb.org/onlinepubs/archive/notesdocs/25-25(29)_fr.pdf)

Maine DOT published an overview of their winter maintenance procedures in 2010 where environmental concerns about salt use are covered in detail.  
<http://www.mcapwa.org/MCSRoadSalt.pdf>

Environmental concerns about salt spreading are covered in great detail here in a report prepared for the National Cooperative Highway Research Program.  
[https://www.google.com/url?sa=t&rct=j&q=&esrc=s&source=web&cd=13&ved=0CDoQFjACOAo&url=http%3A%2F%2Fenvironment.transportation.org%2Fdocuments%2Fnrhp25\\_25\\_files%2Fnrhp\\_chapter\\_8.doc&ei=zGyrUdwTgs\\_LabOdgfAE&usg=AFQjCNEucxto7SIYRvvPyS2zfqNYPCiFEw&sig2=VMJ4KmeghJRfil4VikZIOQ](https://www.google.com/url?sa=t&rct=j&q=&esrc=s&source=web&cd=13&ved=0CDoQFjACOAo&url=http%3A%2F%2Fenvironment.transportation.org%2Fdocuments%2Fnrhp25_25_files%2Fnrhp_chapter_8.doc&ei=zGyrUdwTgs_LabOdgfAE&usg=AFQjCNEucxto7SIYRvvPyS2zfqNYPCiFEw&sig2=VMJ4KmeghJRfil4VikZIOQ)

This study presented at the “8th International Symposium on Snow Removal and Ice Control Technology” has three main focus areas 1) Environmental effects of road salt, 2) Techniques to reduce salt consumption, and 3) Salting policy.

**The Salt SMART Research Program - Optimizing the Salt Use in Norway** by Kai Rune Lysbakken, Aage Sivertsen, Paal Rosland and Joern Ingar Arntsen

## **F. Manufacturers with Fully Automated Spreader Controllers:**

### **AEBI Schmidt**

<http://www.aebi-schmidt.com/en/products/de-icing>

Their automated spreaders:

<http://www.aebi-schmidt.com/en/products/de-icing/390>

### **Giletta**

<http://www.giletta.com/>

### **Epoke**

<http://www.scarab-epoke.co.uk/eposat.html>

### **Monroe**

[www.monroetruck.com](http://www.monroetruck.com)

### **Cirus Controls**

<http://www.ciruscontrols.com/>

### **Nido from Denmark**

<http://www.svenningsens.dk/>

### **Falköping from Sweden**

[www.friggeraker.se](http://www.friggeraker.se)

### **Küpper-Weisser from Germany**

<http://www.kuepper-weisser.de>

### **Bosch-Rexroad**

<http://www.boschrexroth.ca/>

### **Multidrive from UK**

<http://www.multidrivetractors.co.uk/>

## Other Leading Manufacturers:

Great list of spreader manufacturers

<http://www.truckequipmentnetwork.com/spreaders.html>

### Henderson

<http://www.henderson-mfg.com/>

### Teconer Oy

<http://www.teconer.fi/>

### Romaquip from Ireland

<http://www.romaquip.com/>

### Vaisala

<http://www.vaisala.com/en/products/surfacesensors/Pages/default.aspx>

### Certified Power

<http://www.certifiedpower.com/>

### Sicometal from France

<http://www.sicometal.com/>

### CIMLINEYA from China

<http://e-sunhi.en.alibaba.com/>

spreaders here:

[http://e-sunhi.en.alibaba.com/product/510115165-213053601/Self\\_powered\\_hopper\\_spreader\\_CLYR\\_600.html](http://e-sunhi.en.alibaba.com/product/510115165-213053601/Self_powered_hopper_spreader_CLYR_600.html)

## F. Videos cataloged with youtube.com

These videos illustrate various aspects of salt spreaders.

Swenson Electric V-Box Salt Spreader

<http://www.youtube.com/watch?v=SKnPhYOm8F4>

Romaquip Products:

<http://www.youtube.com/watch?v=A6Xtg-bAkWk>

Henderson Products:

Salt Spreader with No Central Hydraulics - Henderson Products

<http://www.youtube.com/watch?v=5GC3r8FEs60>

Henderson First Response Demo (Casper's Truck Equipment)

<http://www.youtube.com/watch?v=-fMR9ByPN4c>

SAND\_SALT\_SPREADER\_CALIBRATION with Paul Brown

<http://www.youtube.com/watch?v=kzTIOG3MxNw>

Winter Operations – installation and calibration of spreader

[http://www.youtube.com/watch?v=fECdIZ\\_XDbc](http://www.youtube.com/watch?v=fECdIZ_XDbc)

Schmidt Stratos - installation

[http://www.youtube.com/watch?v=bDiSU\\_hT9ol](http://www.youtube.com/watch?v=bDiSU_hT9ol)

Schmidt Stratos Spreader

[http://www.youtube.com/watch?v=xI53F\\_YsM1Y](http://www.youtube.com/watch?v=xI53F_YsM1Y)

Rasco Snow Plough - Rasco Salt Spreader.mp4

<http://www.youtube.com/watch?v=r2QLpTnjQzg>

Minnesota Department of Transportation: Clear Roads Project – Field testing of de-icing chemicals.

Short version

<http://www.youtube.com/watch?v=3kWmukTHphU>

Longer version

<http://www.youtube.com/watch?v=cIPTRCXRBDM>

MnDOT's video channel

<http://www.youtube.com/user/rfilipczak?feature=watch>

Mn/DOT Winter Maintenance Chemical & Application Research

<http://www.youtube.com/watch?v=KIWIqdCKoOY>

Just Heavy Equipment #23 - Spreading Salt, Day in the life of a salt spreader,

[http://www.youtube.com/watch?v=LXPKH\\_iPi5w](http://www.youtube.com/watch?v=LXPKH_iPi5w)

Environmental concerns – Fortin Consulting

<http://www.youtube.com/watch?v=2JbW-bXGh5g>

Falkoping\_LB1000\_spreader.wmv

<http://www.youtube.com/watch?v=RWjBTwe3fZc>

## XVIz. Appendix 1: Survey Analysis Report

### Survey for the Development of a Totally Automated Spreading System

#### TABLE OF CONTENTS

Topic	Page
Abstract	44
I. Introduction	45
II. Description	46
III. Findings	47
IV. Conclusions	55
Attachment 1 : Snow fighter Questionnaire	56
Attachment 2 : Vendor Questionnaire	62
Attachment 3 : Potential List of Experienced Personnel	65

**Abstract:**

The technology for developing and implementing an automated chemical spreading system for snow and ice control is proven and demonstrated. The goal of this study is to guide and inform this development by examining the characteristics and capabilities of this technology and exploring the experience of snow fighters and vendors. In addition, the study seeks to investigate the state of this emergent technology and current and future best practices.

As part of this study a survey instrument was developed to determine the degree of confidence and acceptance that exists among the snow fighters and vendors that provide the backbone of the snow and ice removal for the safe operation of roadways for the motoring public. In particular, this survey polled snow fighters and vendors on the current use and future use of these technologies. They were asked their opinion on what they have seen and what they would like to see in this rapidly changing and exciting endeavor to keep the roadways safe, ensure DOT personnel safety, reduce costs and protect the environment.

One critical finding of this study is that snow fighters think controlling the rate of chemicals spread on our road is very important (90%) for road safety and for conserving the amount of chemical (important for costs and the environment). Other important findings of this survey are that vendors in some cases already have a product like this in their product line or are working on one and a significant number (25%) of snow fighting equipment already has some features present on their trucks (like GPS tracking and two-way data communications).

There are also challenges with perception; snow fighters in general (75%) have not embraced the idea that an automated chemical spreader is a reliable idea. This survey has given the professionals in this field a chance to share their experience and to express their concerns about this exciting new technology to determine its usefulness and feasibility.



## I. INTRODUCTION

Controlling the amount of material distributed to the road surface during the snow and ice removal process has gained new attention with recent advances in technology and variety of chemical available. Feedback control of chemical spreaders for snow and ice control on our roads (controlling the amount of chemical distribution with the speed of the vehicle) is an old technique that is changing rapidly; witness the new onboard sensors that can regulate amount of chemical (e.g., surface temperature, GPS receiver). The function of this survey of snow fighters and spread controller vendors is to:

- identify category experts
- document successes and problems
- investigate the functionality of systems currently available or imminently available
- determine how professionals view this development and where they would like to see progress occurring

A diagram of the overall project objective is shown in Figure 1.

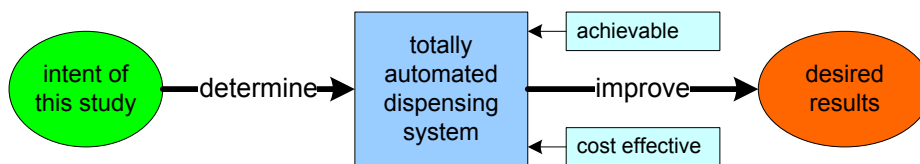

**Figure 1: Project Objective**

The responses to the surveys were varied and focused at the same time. For example, one of the respondents commented as follows, “The concept of fully automated spreading based on a set of parameters is of interest and would be used in certain applications and areas. However, the ability to think and evaluate and make a rational decision by an operator based on circumstances that cannot be programmed logically will always be present. Therefore, the operator will always have to have some say.” This response was indicative of the feedback of many of the participants in our survey. The desired results from Figure 1 are achievable and cost-effective only if applied correctly.

**A. Background.** We are experiencing a state of constant development in the area of chemical spreaders for snow and ice management on our road surfaces. New products are being developed and introduced every season.

The Clear Roads ([www.clearroads.org](http://www.clearroads.org)) pooled fund research program, in coordination with the Minnesota Department of Transportation, seeks to develop guides and guidelines for the development and utilization of these technologies.

***One of our preliminary steps in the development of these guides is the presentation of a survey.*** The survey process seeks to gather information from respondents working in this area of expertise. We offered the survey to two groups: snow fighters (most were government

employees working in the snow and ice removal community) and vendors/manufacturers of spread controllers.

**B. Purpose.** The purpose of these survey instruments is to provide a forum for government agencies and vendors/manufacturers a chance to pool their expertise and opinions to come up with some general directions and some broad industry guidelines for the development and practical application of this technology. Since the respondents include a field of highly proficient experts, vendors with a great deal of experience and talented researchers, we hope to provide a repository of knowledge that will influence development and provide insight pointing to best practices in the efficient and creative application of this technology to our ever present challenge of providing safe roadways to the motoring public.

## **II. DESCRIPTION**

**A. Approach.** We approached this effort from two perspectives: snow fighters and vendors. We sought to gather the opinions and experience of these two groups on their views concerning the state of the automated spreader technology and the feasibility and desirability of future products and approaches. Even though the overall goal of creating safe roadways is the same, these two groups needed separate surveys to express themselves properly. The respondents were given the opportunity to take ownership of their responses or remain anonymous.

**B. Scope.** In conducting this survey, we sought out experts and stakeholders that have expertise in this field. We did not seek to gather random data or to form an opinion poll seeking a majority or a “let’s vote” approach on the best method. All were invited to participate and the survey was offered online without any proprietary identification or password required. It was announced on the electronic bulletin board for snow and ice professionals (listserv) and distributed to organizations such as American Public Works Association (APWA) members, American Association of State Highway & Transportation Officials (AASHTO) members, and Transportation Research Board (TRB) Winter Maintenance Subcommittee members. We also asked, in the survey, for suggestions of who might have valuable input and these people were also invited to take the survey.

**C. Question Preparation.** The list of questions for each of the two surveys can be found in Attachments 1 and 2. In consultation with perspective survey candidates and the Clear Roads technical advisory committee we generated a set of questions that would achieve our goals. The surveys, 30 questions for the snow fighters and 16 questions for the vendors, could be completed in 10 minutes or less. By far the most productive and easiest method of dispersion was to make the survey available on the [www.clearroads.com](http://www.clearroads.com) website and then notify people of its presence with an email including a website address for the survey.

**D. Testing & Publishing.** Using a select group of candidates, the surveys were tested online. Clarity, consistency and completeness were checked and the integrity of the data was verified.

Corrections, modifications, and question editing was accomplished based on the candidate feedback. The site was published on the website ready for responses in early August 2012. The data was gathered through November 2012.

**E. Invites to Potential Responders.** Email invitations were sent to each of the Clear Roads member organizations, selected APWA, AASHTO, and TRB members asking each member to complete the survey and to invite other interested parties. We also posted the survey on the snow and ice listserv hosted by the University of Iowa. Vendors were invited to participate from the listserv and additional vendors, most of whom had government agencies as data collection customers, were included. We searched for interested vendors, many generated by the literature search, and invited them to complete the vendor survey. Again, we asked for internal distribution within their organization. Several of the individuals from the vendor category chose to participate with one voice for their company, hence the fewer number of responses from the vendor survey.

### III. FINDINGS:

#### A. Who took the survey and what is the nature of their snow-fighting fleet

There were 173 participants in the survey: 161 snow fighters and 12 vendors. Of the snow fighters, 90% were state government employees and 10% were county and municipal employees. They were from over 19 different US states and Canadian Provinces. The sample represented a large variety of snow fighting fleets. The age of vehicles tended to be older as seen in Table 1 below.

<b>Table 1. Average age of snow fighting vehicles</b>	<b>Response Percent</b>
3 years or less	1.3%
4-6 years	51.0%
7-10 years	47.7%

The number of operators per respondent was equally distributed as shown in the chart below (See Figure 2).

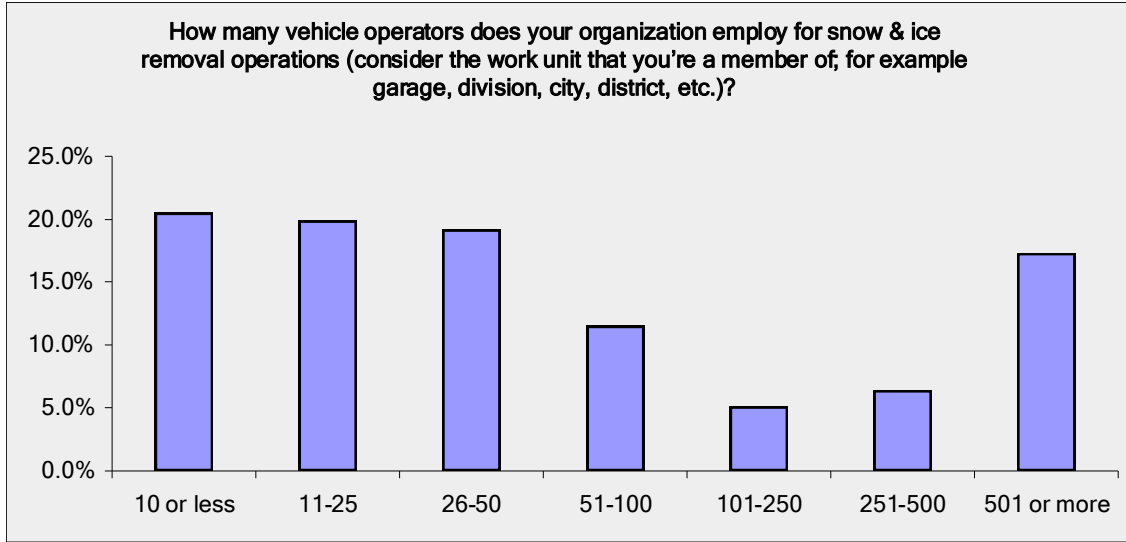

**Figure 2: Vehicle Operators/Organization**

Nine different vendors were represented and half of the people responding were engineers with the remainder comprised of managers and salespeople.

See Attachment 3 for a list of experts willing to share their contact information for future reference.

**B. How important is it to monitor/control the spread rates of chemicals?**

Two different questions were asked of the snow fighters about the importance of controlling the spread rate of chemicals: one about road safety and one about limiting the use of chemicals on the roadways. The responses to the questions elicited the same percentages; 90% felt it was very or extremely important to control spread rate and only 10% thought timing and frequency of treatment more important. Clearly, controlling spread rate is a top priority.

**C. How is spread rate set/controlled now on most snow fighting vehicles?**

Regarding the type of control currently in use, we found an even split between open- and closed-loop systems.

Two questions about who controls the spread rate were asked of the snow fighters with the following results (See Tables 2 & 3).

<b>Table 2. How should the rate of chemicals be set by your organization?</b>	<b>Response Percent</b>
Vehicle operator	49.7%
Road maintenance supervisor	40.9%
Transportation director	1.3%

Factory set by the manufacturer	0.0%
Automatically based on storm conditions and location	7.4%
Don't know	0.7%

<b>Table 3. How is the rate of chemicals set by your organization?</b>	<b>Response Percent</b>
Each driver sets their rate as needed by the storm conditions	52.4%
Our organization provides a standard spread rate for all vehicle operators to maintain	42.2%
Our trucks have a firm spread rate that is locked in based on the spread controller or the gate and is not changeable by the vehicle operator	2.0%
Each supervisor has access to the spread controller and can adjust the rate based on storm conditions for each vehicle in their fleet	3.4%

A further question pertaining to this, since about half of the vehicles spread rate is controlled by the drivers, was “Is controlling the spread rate a distraction for the drivers?” Twenty-three percent said yes, and 77% said no.

**C. Is an automated spreader a good idea?**

The question of receptivity to an automated spreader was asked in four different ways in the survey with some interesting results. The following table compares the percentage of “yes” responses to the questions.

<b>Table 4. Different forms of the question.</b>	<b>Percent “yes”</b>
Do you embrace the concept of controlling the spread rate either automatically from a central location in your organization or from a software program installed on the spread controller prior to plowing the route?	27.4%
Would you be receptive to a totally automated spread controller with an option that takes (almost) all control of the spread rate away from the truck operator because of the operational complexity (resources & safety) of today’s snow & ice removal equipment?	21.5%
Do you embrace the concept of pre-programming the in-vehicle spread controller to distribute chemicals at a predetermined rate based on location (using a GPS system)?	20.7%

Table 4. Different forms of the question.	Percent “yes”
Do you embrace the concept of an in-vehicle automatic spread controller that can be controlled wirelessly from a central location (by a supervisor) based on changing weather or storm conditions?	16.0%

There is a great deal of resistance to the idea that automating the spreader is a good idea (73% – 86%). With the inevitability of this technology, results of this survey suggest future guides to implementation may want to include a section on the motivation behind this technology and education about its efficiency and creativity.

#### D. What features would it have?

**Logic of controllers:** There are several ways to automate a spread controller; one way to visualize the options is with the following table shown below (See Figure 3). The two vertical columns are labeled “automated” and “manual” and the two horizontal rows are labeled “headquarters” and “vehicle”. The characteristics of each of the four scenarios are summarized within the corresponding four cells. The following definitions apply:

- **Headquarters** designates that the spread controller can be operated remotely from a centralized location.
- **Vehicle** signifies that the spread controller is automated using pre-programmed firmware and reacts to an on-vehicle sensor.
- **Automated** signifies that the spread controller is not controlled by the operator.
- **Manual** means that the spread controller is controlled by the vehicle operator.

Controlled by	Automated	Manual
Headquarters	<ul style="list-style-type: none"> <li>• Need wireless communications</li> <li>• Advantages of responding globally</li> <li>• Easy to track chemical use</li> <li>• Can use information from law enforcement and weather services quickly</li> </ul>	<ul style="list-style-type: none"> <li>• Need wireless communications</li> <li>• Global response</li> <li>• Requires experienced personnel at headquarters</li> </ul>
Vehicle	<ul style="list-style-type: none"> <li>• Respond locally to weather/road conditions</li> <li>• Local conditions are more accurate</li> <li>• Add more sensors as they become available</li> </ul>	<ul style="list-style-type: none"> <li>• No need to rely on technology</li> <li>• Respond instantly to local conditions using operator experience and observation skills</li> </ul>

Figure 3: Table of Automated Options

The vendors were asked the following question, “If your organization were to develop and offer for sale a spread controller with automatic (location and storm severity adjusted) spread control capability, how do you feel the spread rate should be set on each vehicle?” Fifty percent

said they would use headquarters approach and 83% said they would use both the headquarters and the in-vehicle approach.

**Controlling Input:** Both the snow fighters and the vendors were asked this question; “If a spread controller with automatic pre-programming capability becomes available, what triggers or inputs should be used to control or influence the determination of the distribution rate (granular, liquid, mixture)? (Check all that apply)”. See Table 5.

<b>Table 5. Triggers/inputs that should be used to control the rate.</b>	<b>Snow Fighters</b>	<b>Vendors</b>
Location	51.7%	75.0%
Road surface temperature	59.7%	91.7%
Air temperature	48.3%	33.3%
Time of day	53.7%	41.7%
Treatment options (type of chemical available)	57.7%	50.0%
Plow position or configuration	25.5%	8.3%
Other	10.7%	33.3%
All of the above	52.3%	16.7%
None of the above	6.0%	0.0%

A considerable number of respondents (over 50%) responded that all of these inputs would/could be valuable in the control of the spread rate. A couple respondents also said the general weather forecast and conditions are also an important input to this process.

**E. Is it feasible and on what sort of time table?**

Three features of existing equipment were explored as far as existing equipment goes; GPS systems, wireless systems, engine bus connections. The existence and usability of these systems impacts only the “headquarters approach” as an onboard control would not need these features. The following figure from the vendor survey indicates vendors think an automated spreader is feasible. See Figure 4.

**Wireless systems:** The most important feature for the headquarters approach is a wireless system for communicating with the trucks. Of the respondents, 26% already have a wireless modem sending and receiving information from the trucks and of these, 52% use a cellular connection.

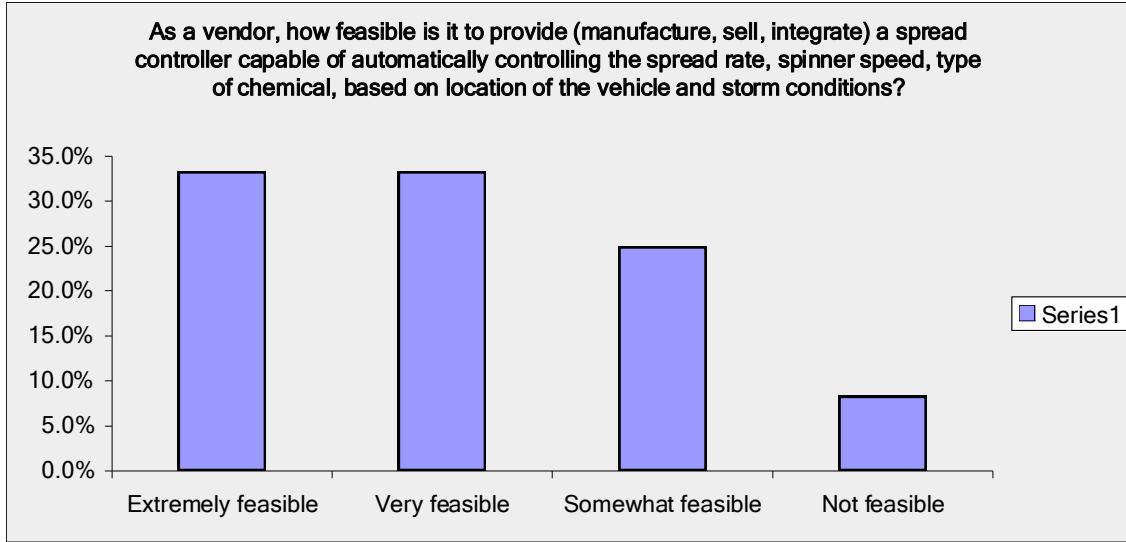

**Figure 4: Feasibility of Automation**

**Engine bus connection:** This technology is important for both the headquarters approach and the in-vehicle approach as this is the easiest way to get sensor information to the spreader and to headquarters. Almost one-fifth of the snow fighters collect information already from the engine bus.

**The state of GPS information:**

Snow fighters were asked if their trucks with spreaders use GPS for location with the following results. See Table 6.

Table 6. Do your spreaders have a GPS device	Response Percent
Yes...it is a separate GPS device	18.6%
Yes...it is an embedded device internal to the spread controller	8.3%
No	66.7%
Don't know	6.4%

The following figure from the vendor survey indicates vendors are ready for an automated spreader. See Figure 5.



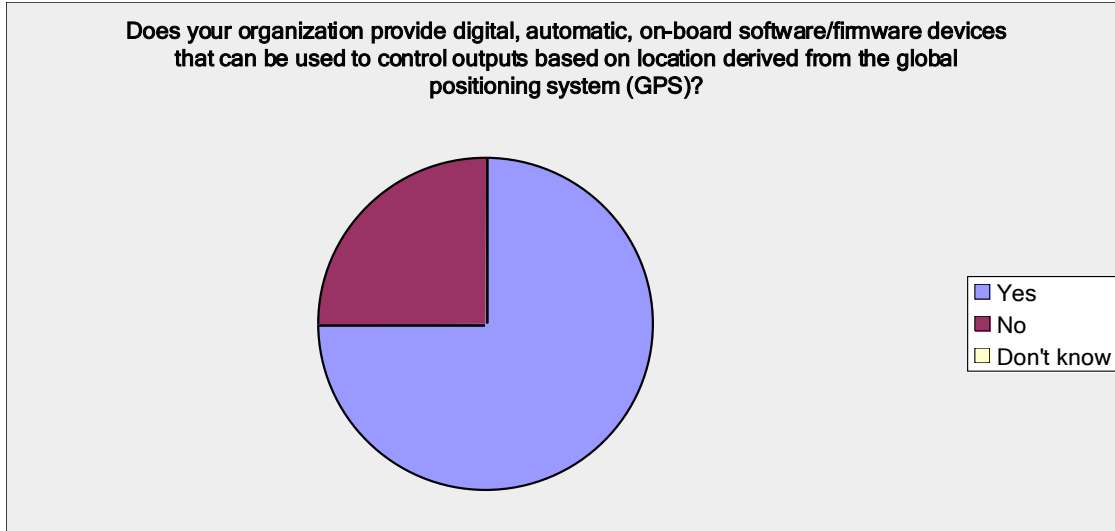

**Figure 5: Location Control from Onboard GPS**

The vendors were also asked, “Do you feel that the present accuracy of a GPS receiver is sufficient to control the spread rate of snow and ice removal chemicals automatically?” The results are summarized in Table 7.

<b>Table 7. Is GPS accurate enough to control the spread of chemicals?</b>	<b>Response Percent</b>
Yes	33.3%
No	16.7%
Only in a rural or highway environment	41.7%
Only in an urban environment	0.0%
Don't know	8.3%

There was a significant amount of skepticism in this area about the comprehensive use of GPS in this application.

**Response time and accuracy:**

There has been some concern that response time of an automated spreader would limit its usefulness in snow and ice applications. The vendors were asked, “One of the challenges to an automatic spread controller is the response time of the on-board system (hydraulics, sensors, spinner, gate, auger, etc.). The spread rate changes may be slow to react to change in location or storm conditions at snow and ice removal at roadway speeds. Do you feel this is a problem?” Half said “yes”, 33% said “no” and 17% said “don’t know”.

## F. What ramifications would there be of the implementation of an automated spreader system?

**Information:** First, we will talk about information gathering. The question was asked of the snow fighters; “How useful would automated records of materials spread at what location be to you?” Ninety-three percent thought this would be very useful or somewhat useful. When asked how the information could be used, the response was as follows. See Table 8

<b>Table 8. What would you use this information for?</b>	<b>Response Percent</b>
Risk management and/ or lawsuit reduction	53.1%
Resource tracking	77.6%
Training of individual operators	76.9%
Continuous improvement of the winter maintenance program	89.1%
Performance measurement	58.5%

### **Environmental concerns:**

The vendors were asked if an automated spreader controlled from headquarters would reduce the amount of chemicals spread on the roads. Half said “yes” and 8% said “no” and 42% were unsure.

Also, the snow fighters were asked “How important is controlling the spread rate to better husband the use of snow and ice removal chemicals to limit costs and still maintain safe roadways?” Nine out of ten said it was “extremely” or “very” important, highlighting the interest snow fighters have in finding ways to better utilize these chemicals.

### **Safety concerns:**

Obviously safety for both public roadways and snow fighters is the reason we are talking about this topic in the first place. When asked “How important is controlling the spread rate to the success of removing snow and ice from the roadways during a snow & ice storm?” 90% of the snow fighters said it was “extremely” or “very” important.

As mentioned previously, only one-quarter of the drivers felt that controlling the spread rate is a distraction to the driver yet to those respondents this does present a potential safety hazard.

**Liability:** The vendors were asked, “Any system which includes automatic control or preset factory control will raise the issue of liability. Do you feel that a vendor will assume a change in liability if the spread controller they provide to snow and ice removal agencies has an automatic spread control feature?” Their response was as follows. See Table 9.

<b>Table 9. Would automating the spreader affect manufacturer liability.</b>	<b>Response Percent</b>
Yes	8.3%
No	41.7%
Increase liability	41.7%
Decrease liability	0.0%
Don't know	8.3%

This reflects either an uncertainty about this issue or different opinions about these legal concerns.

#### **IV. Conclusion:**

The inevitability of automated equipment is being realized now and this study seeks to accurately prepare the snow and ice community in anticipation of its arrival and to get a feel for stakeholder concerns. The following points are meant to summarize many of the findings.

- This survey was well received and provided very valuable information.
- Accurately controlling the spread of chemicals on our roads is recognized by snow fighting professionals to be a very important aspect of keeping our roadways safe and operable during snow and ice conditions.
- The automated chemical spreader for snow and ice control is feasible and its use will be increasing in the coming years.
- With some resistance to the concept in the ranks of snow fighters, we want to encourage education as part of the process.
- With the fact that many of the pieces of this technology are already incorporated in the snow plows, the immediate need for guidelines and best practices is significant.
- The potential advantages of information gathering and more efficient use of road-clearing chemicals for safety and for the environment point out the advantages of further development of this technology.
- Much more research is needed in the areas of response time, liability, and method of control to determine the best practices for each situation.

#### **Attachments:**

**Attachment 1: Snow fighter survey questions**

**Attachment 2: Vender survey questions**

**Attachment 3: List of respondents as a pool of experts in this area**

## Attachment 1: Snow fighter Questionnaire

### Questions for SNOW FIGHTERS (Operators, Supervisors, and Managers)

1. How many snow and ice removal vehicles are used by your organization (consider the work unit that you're a member of; for example garage, division, city, district, etc.)?

- 10 or less
- 11-25
- 26-50
- 51-100
- 101-250
- 251-500
- 501 or more

2. How many vehicle operators does your organization employ for snow and ice removal operations (consider the work unit that you're a member of; for example garage, division, city, district, etc.)?

- 10 or less
- 11-25
- 26-50
- 51-100
- 101-250
- 251-500
- 501 or more

3. What is the average age of the vehicles that perform snow and ice removal operations? Provide your best estimate.

- 3 years or less
- 4-6 years
- 7-10 years
- more than 10 years

4. What type of spread controller system do you use on your vehicles to control the distribution of snow and ice chemicals (granular or liquid) on road surfaces? (check all that apply)

- Manual
- Open loop automatic
- Closed loop automatic
- Don't know

5. Does the system use the Global Positioning System for determining location of the vehicle and spread controller?

- Yes, it is a separate GPS device
- Yes, it is an embedded device internal to the spread controller
- No

Don't know

6. What other type of snow and ice removal equipment (attachments and/or accessories) is/are used on your snowplows during the winter season? (Check all that apply)

Infrared road surface temperature sensor

Plow (front, wing, underbody, etc.)

Chemical spread controller

Engine data (connecting to the engine bus using J1708 or J1939 connector)

Two way data messaging

Automatic vehicle location system

Other

None

7. Do you use a wireless modem for sending/receiving data from your snow and ice removal vehicles?

Yes

No

Don't know

**Questions 8-13 are directed towards supervisors, however, if you know a response please provide. Otherwise, please continue with question 14.**

8. If yes, what type of wireless radio/carrier is it?

Cellular carrier

Internal radio system

Satellite communications

Wi-Fi or 802.11B/G

900 Mhz system

Other

9. If you answered cellular in the above question, which service provider do you use?

Sprint (code division multiple access (CDMA))

AT&T (general packet radio service (GPRS))

Verizon (code division multiple access (GPRS))

Nextel (integrated digital enhanced network (iDEN))

T-Mobile (general packet radio service (GPRS))

Other

10. Do you collect information from the engine bus on your vehicles?

Yes

No

Don't know

11. If yes, what method of collection do you use?

- Direct connection with a cable and a laptop, downloading the controller area network (CAN) bus information
- Cable connect with a factory provided diagnostic tool that downloads the CAN bus information
- Wirelessly with a CAN bus connector & wireless modem (cellular, satellite, wi-fi, radio)
- Don't know

12. What interface do your vehicles provide for on-board information of the engine, transmission, tires, and accessories?

- Society of Automotive Engineers (SAE) J1708
- Society of Automotive Engineers (SAE) J1939
- Original Equipment Manufacturer (OEM) proprietary bus
- Other
- Don't know

13. How is the spread rate for granular and liquid snow and ice removal chemicals set by your vehicle operators?

- Each driver sets their rate as needed by the storm conditions
- Our organization provides a standard spread rate for all vehicle operators to maintain  
If so, how is this accomplished (number on board, radio call, etc.)?  
Specify \_\_\_\_\_
- Our trucks have a firm spread rate that is locked in based on the spread controller or the gate and is not changeable by the vehicle operator
- Each supervisor has access to the spread controller and can adjust the rate based on storm conditions for each vehicle in their fleet

**All responders continue.**

14. How important is controlling the spread rate to the success of removing snow and ice from the roadways during a snow and ice storm?

- Extremely important
- Very Important
- The rate is not as important as the timing and frequency of treatment
- Less important
- Not important

15. How important is the controlling the spread rate to better husband the use of snow and ice removal chemicals to limit costs and still maintain safe roadways?

- Extremely important
- Very Important
- The rate is not as important as the timing and frequency of treatment
- Less important
- Not important

16. Do you feel that controlling the spread rate of the snow and ice chemicals while the vehicle is treating the roadway is a distraction to the driver (turning off/on, changing rate, using blast button, adding liquid, changing chemicals)?

- Yes
- No
- Don't know

17. As a snow fighter, do you embrace the concept of controlling the spread rate either automatically from a central location in your organization or from a software program installed on the spread controller prior to plowing the route?

- Yes
- No
- Don't know

18. As a snow fighter, do you embrace the concept of preprogramming the in-vehicle spread controller to distribute chemicals at a predetermined rate based on location (using a GPS system)?

- Yes
- No
- Don't know

19. As a snow fighter, do you embrace the concept of an in-vehicle automatic spread controller that can be controlled wirelessly from a central location (by a supervisor) based on changing weather or storm conditions?

- Yes
- No
- Don't know

20. Who should determine the distribution rate of snow and ice removal chemicals in your organization?

- Vehicle operator
- Road maintenance supervisor
- Transportation director
- Factory set by the manufacturer
- Automatically based on storm conditions and location
- Don't know

21. If a spread controller with automatic pre-programming capability becomes available, what triggers or inputs should be used to control or influence the determination of the distribution rate (granular, liquid, mixture)? (check all that apply)

- Location
- Road surface temperature
- Air temperature
- Time of day

- Treatment options (type of chemical available)
- Plow position or configuration
- Other
- All of the above
- None of the above

22. Would you be receptive to a totally automated spread controller with an option that takes (almost) all control of the spread rate away from the truck operator because of the operational complexity (resources & safety) of today's snow and ice removal equipment?

- Yes
- No
- Other

23. How useful would automated records of what materials were spread at what locations be to you and your organization?

- Very useful
- Somewhat useful
- Not useful

24. If you had that information, would you use it for (check all that apply):

- Risk management and/or lawsuit reduction
- Resource tracking
- Training of individual operators
- Continuous improvement of the winter maintenance program
- Performance measurement
- Other Specify \_\_\_\_\_

25. What type of agency are you representing for this survey?

- Federal government
- State government
- County government
- City/town government
- Out-source contractor working for local government
- Other Specify \_\_\_\_\_

26. Please enter the following: (optional)

- Your name \_\_\_\_\_
- Your title \_\_\_\_\_
- Your organization \_\_\_\_\_
- Your email address \_\_\_\_\_

27. How did you hear about or find this questionnaire?

- Notified by email
- Referred by Clear Roads Organization



- Referred by American Public Works Association (APWA)
- Referred by other professional organization or society
- Referred by colleague or friend
- Other

28. Do you have other ideas on this topic and how best to limit the use of chemicals on the roadways yet maintain a safe driving road surface for the motoring public and the winter maintenance personnel?

---

## Attachment 2: Vendor Questionnaire

### Questions for spread control and snow & ice removal equipment VENDORS

1. What type of organization are you representing for this survey?

- Manufacturing
- Consulting
- Systems integrator
- Snow and ice specialist
- Sales and marketing representative
- Other                      Specify \_\_\_\_\_

2. Which portrayal below best fits your job description?

- Management, executive, supervisor
- Marketing, sales
- Financial, procurement,
- Engineering, technician, designer
- Other                      Specify \_\_\_\_\_

3. What industries does your organization participate with your products and services? (check all that apply)

- Snow and ice removal, road treatment equipment, plows, etc.
- Agriculture
- Public services
- Fire fighting
- Law enforcement
- Emergency services
- Heavy equipment
- Transportation
- Communications
- Systems integration
- Vehicle tracking, data gathering, information services
- Chemical treatment, salt, snow and ice treatment, granular, liquid, mixtures
- Spread controllers
- Plows and other snow-fighting accessories
- Other                      Specify \_\_\_\_\_

4. Does your organization provide digital, automatic, on-board software/firmware devices that can be used to control outputs based on location derived from the global positioning system (GPS)?

- Yes
- No
- Don't know

5. As a vendor, how feasible is it to provide (manufacture, sell, integrate) a spread controller capable of automatically controlling the spread rate, spinner speed, type of chemical, based on location of the vehicle and storm conditions?

- Extremely feasible
- Very feasible
- Somewhat feasible
- Not feasible

6. One of the challenges to an automatic spread controller is the response time of the on-board system (hydraulics, sensors, spinner, gate, auger, etc.). The spread rate changes may be slow to react to change in location or storm conditions at snow and ice removal vehicle speeds. Do you feel this is a problem?

- Yes
- No
- Don't know

7. As a vendor, do you embrace the concept that automatically controlling the spread rate (pre-programmed or centrally) from the storm center will reduce the amount of chemicals distributed on the roadway to fight snow and ice storms, yet assist in providing a safe roadway for the motoring public and road maintenance personnel?

- Yes
- No
- Don't know
- Other

8. If your organization were to develop and offer for sale a spread controller with automatic (location and storm severity adjusted) spread control capability, how do you feel the spread rate should be set on each vehicle?

- Use a pre-programmed set of instructions within the spread controller on-board firmware?
- Use a wireless system to change spread rates from a central storm fighting location that is addressable to each vehicle
- Both of these methods
- None of these methods
- Other

9. Do you feel that the present accuracy of a GPS receiver is sufficient to control the spread rate of snow and ice removal chemicals automatically?

- Yes
- No
- Only in a rural or highway environment
- Only in an urban environment
- Don't know

10. If a spread controller with automatic pre-programming capability becomes available, what triggers or inputs should be used to control or influence the determination of the distribution rate (granular, liquid, mixture)? (check all that apply)

- Location
- Road surface temperature
- Air temperature
- Time of day
- Treatment options (type of chemical available)
- Plow position or configuration
- Other Specify \_\_\_\_\_
- All of the above
- None of the above

11. Any system which includes automatic control or preset factory control will raise the issue of liability. Do you feel that a vendor will assume a change in liability if the spread controller they provide to snow and ice removal agencies has an automatic spread control feature?

- Yes
- No
- Increase liability
- Decrease liability
- Don't know

12. Do you have other ideas on this topic and how best to limit the use of chemicals on the roadways yet maintain a safe driving road surface for the motoring public and the winter maintenance personnel?

\_\_\_\_\_

13. Your information:

- Name \_\_\_\_\_
- Organization \_\_\_\_\_
- Title \_\_\_\_\_
- Email address \_\_\_\_\_

14. How did you hear about or find this questionnaire?

- Notified by email
- Referred by Clear Roads Organization
- Referred by American Public Works Association (APWA)
- Referred by other professional organization or society
- Referred by colleague or friend
- Other Specify \_\_\_\_\_

**Attachment 3: The Respondents:**

NAME	EMAIL	ORGANIZATION
Ronnie Swogar	swogar@ksdot.org	KDOT - PSA1
Jason Kreps	jason.kreps@dot.state.co.us	5719/TMI
Peter Chladil	pchladil@waukeshacounty.gov	Waukesha County DPW/Highway Operations Division Highway Operations Manager
Raymond T. Bergin	rbergin@dot.state.ny.us	NYS DOT/ Supervisor
Steve	pepinhwy@nelson-tel.net	Pepin County Highway Dept.
Shane Williamson	scwilliamson@utah.gov	Utah Department of Transportation/ Maintenance Supervisor
Jeffrey D. Boone	jdboone@nysdot.gov	hms 1
kenn. gillette	kgillette@utah.gov	road shed forman
Bryan Pickworth	bpickworth@fhgov.com	City of Farmington Hills-DPW, Road Maint. Supervisor
William J. Gorski	bgorski@dot.state.ny.us	NYS DOT, Snowfighter, Highway Maintenance Supervisor 2.
Kris	kris.baguhn@co.marathon.wi.us	Marathon Co. Hwy./ snowfighter
Troy Esterholdt	testerholdt@utah.gov	UDOT maintenance supervisor
Kevon Ogden	kevonogden@utah.gov	UDOT Area supervisor
Mike Randolph	mrandolph@utah.gov	UDOT/Station Supervisor
Todd Gibbs	tgibbs@utah.gov	UDOT Supervisor
Mike Kiley	mike.kiley@state.mn.us	Clearroads/snow fighter
Keith Meinhardt	kmeinhardt@utah.gov	UDOT
Chris Ransom	cransom@utah.gov	UDOT/Manager
Joe Engle	jengle@ksdot.org	KDOT Supervisor
Mike Bohm	yworry@yahoo.com	state highway snow fighter
Darrin Heater	darrin.heater@dot.ny.gov	NYS DOT highway maintenance supervisor
W. James Smith	walsmith.gov	PennDOT/ Chief Fleet Management
Shawn Hauck	smhauck@nd.gov	NDDOT/Equipment Manager
Monty Mills	millsm@wsdot.wa.gov	WSDOT
Robt Richter	Robert.Richter@dot.ny.gov	NYS DOT - Resident Engineer
Thad Ash	tash@co.door.wi.us	Door CVounty Highway Dept./ Patrol Superintendent
Ron Munyan	munyan@ksdot.org	KDOT Maintenance Superintendent
Lloyd		UDOT Station Supervisor
Steve Williams	swilliams@dot.state.nv.us	NDOT Hwy Maint. Manager
Mike Wickens	mwickens@utah.gov	UDOT
Neil Pierce	pierce@co.rock.wi.us	Rock County DPW/ Highway Supt
Michael Hollis	hollis@ks.dot.org	KDOT supervisor & operator
Bret Hodne	bret.hodne@wdm.iowa.gov	City of West Des Moines - Public Works Director
Lynn Bernhard	lynnbernhard@utah.gov	UDOT Central Maintenance
brad vance	bvvance@gmail.com	Mndot
Dan Etl		CDOT
Jeremy Gjovik	jeremy.gjovik@state.mn.us	MnDot Transportation Operations Supervisor
Branco Vlacich	Branco.Vlacich@VDOT.Virginia.gov	VDOT/Snow fighter
Mike Fayette		NYS DOT Essex County Resident Engineer

NAME	EMAIL	ORGANIZATION
Annette Dunn	annette.dunn@dot.iowa.gov	Iowa DOT
M Gennaro	mgennaro@dot.state.ny.us	NYSDOT
Robert Dunning	robert.dunning@alaska.gov	State of Alaska District Superintendent Maintenance and Operations Vladez District
Mitch Roth	Mitch.roth@dot.state.mn	Dept. Of Trans. Area TGS
Max Perchanok	max.perchanok@ontario.ca	Ontario Ministry of Transportation/researcher
Bryant Richins	brichins@utah.gov	UDOT/Snowfighter
Allen Williams	allen.williams@vdot.virginia.gov	VDOT/District Maintenance Engineer
Kenneth Relation	kenneth.relation@dot.ny.gov	New York State Dept. of Transportation / Storm Manager
Dan Whebbe	daniel.whebbe@state.mn.us	MnDOT TOS2
Jason Brown		MnDOT
Gary Steele	gsteele@utah.gov	
Mike Mattison	mike.mattison@nebraska.gov	Nebraska Dept. of Roads
Gary Moulin	garym@ksdot.org	Kansas Dept of Transportation
Ken Washatko	kwashatko@co.langlade.wi.us	Patrol Superintendent
Lou Cardinale	louis.cardinale@dot.ny.gov	Supervisor
William Bell	bbell@ksdot.org	KDOT/psa1-snow fighter
Jerry Lopez	jerry.l.lopez@dot.state.co.us	CDOT- TM-II
Randy Reznicek	Randy.Reznicek	MnDot ClearRoads
George Clarke	george.clarke@dot.ny.gov	NYSDOT/snow fighter - supervisor
Scott McIntyre	smcintyre@ci.omaha.new.us	Omaha Public Works
Mario Montano	mario.montano@dot.state.co.us	CDOT/EOIII
Donald Holdridge	donald.holdridge@dot.state.co.us	CDOT Maintenance/TMill
Jeff Pope	Jeff.pope@dot.state.co.us	
John Klostermann	jkloster@cityofdubuque.org	City of Dubuque Maintenance Supervisor
James J. Murawski	James.Murawski@dot.ny.gov	NYSDOT Hwy Maint./Asst Res Engineer
Mark Willsey	Mark.Willsey@dot.ny.gov	Snow fighter
Joseph M. Bush	jbush@dot.state.ny.us	NYS Dept of Trans/Trainer Supervisor
Tim	tbaker@dot.state.ny.us	NYSDOT/MEC
Don Nabors	bigd31053@optonline.net	NYSDOT
M.T. (Vijay) Vijayendran	m.t.vijay.vijayendran@do.ny.gov	NYSDOT; Resident Engineer
Ben Dow	bdow@cityoffargo.com	City of Fargo Director of Public Works
Jasper Casias	jasper.casias@state.co	TM-1
Mike	Bowen	UDOT
jed mulder	jed.mulder@state.mn.us	Lake area TOS 2
Dale Lusti	dale.e.lusti@state.mn.us	MnDOT
Jeff	lukken@countyofdane.com	DANE COUNTY HIGHWAY DEPT. Shop Supervisor
jim streit	jamesstreit@state.mn.us	MnDOT
scott allen	ScottA@ksdot.org	KDOT
William C. Sube	bsube@utah.gov	UDOT
Steve Spoor	steve.spoor@itd.idaho.gov	Idaho Transportation Department - Mtce Services Manager/Fleet Manager
Mike Keichinger	mkeichinger@co.juneau.wi.us	Juneau County Public Works State Supervisor
jim crow	fdpw@msn.com	village of fayetteville dpw,new york supt.

<b>NAME</b>	<b>EMAIL</b>	<b>ORGANIZATION</b>
George R McCool Sr	george.mccool@state.vt.us	VT. AOT Assistant MTA
George R McCool Sr	george.mccool@state.vt.us	VT. AOT, Operations Assistant MTA
Steve Birmingham	steve.birmingham@ontario.ca	Ontario Ministry of Transportation - Maintenance Officer
Neil Lundell	nlundell@utah.gov	UDOT Sta.3425 Station Supervisor
Mike Davis	mike.davis@state.co.us	TM-III
Roger Frantz	rfrantz@utah.gov	UDOT Station Supervisor
Mike Temple	Michael.Temple@dot.ny.gov	NYSDOT Maintenance Manager
Caleb Dobbins	cdobbins@dot.state.nh.us	NHDOT/State Maint Engineer
Gerald Watts	gjwatts@dot.state.ny.us	NYSDOT HMS-2
David Brown	davidbrown@utah.gov	UDOT Roadway operations manger
butch dimick	raymond.dimick@dot.ny.gov	nysdot/supervisor
Philip J. DeSain		EOI
Vincer Lauricella	vlauricella@dot.ny.gov	NYSDOT / Operations Engineer
Mike Loftus	michael.loftus@thruway.ny.gov	Toll Road/Program Director
Jeff Tice	jtice@ksdot.org	assistant eq. mang.
Steve Barnes	Steve.Barnes@state.co.us	CDOT TM-1
Troy Whitworth	troy@ksdot.org	Kansas DOT; Clear Roads
Tyler Wagstaff	twagstaff@utah.gov	UDOT Trans Tech Three
Brian Burne	Brian.Burne@maine.gov	MaineDOT Highway Maintenance Engineer
Gardi Willis	gwillis@csroads.com	Fleet Logic Global, LLC
Robert Henningsgard	rob@ciruscontrols.com	Cirus Controls, Director - Telematics Products
Taisto Haavasoja	taisto.haavasoja@teconer.fi	Teconer Ltd, CEO
Dennis C. Koering	koering@comcast.net	Monroe Truck Equipment, Western Region Sales Manager
Robert Roszell	robert@relinks.ca	RELinks - CEO
Jun Zhang	jun.zhang@boschrexroth.ca	Bosch Rexroth
Bob Lannert	mosnowking@aol.com	Owner Snow King Tech - TowPLows